

# Service Manual



## **MTX100B MPEG Recorder & Player 071-1929-00**

### **Warning**

The servicing instructions are for use by qualified personnel only. To avoid personal injury, do not perform any servicing unless you are qualified to do so. Refer to all safety summaries prior to performing service.

**[www.tektronix.com](http://www.tektronix.com)**

Copyright © Tektronix. All rights reserved. Licensed software products are owned by Tektronix or its subsidiaries or suppliers, and are protected by national copyright laws and international treaty provisions.

Tektronix products are covered by U.S. and foreign patents, issued and pending. Information in this publication supercedes that in all previously published material. Specifications and price change privileges reserved.

TEKTRONIX and TEK are registered trademarks of Tektronix, Inc.

## **Contacting Tektronix**

Tektronix, Inc.  
14200 SW Karl Braun Drive  
P.O. Box 500  
Beaverton, OR 97077  
USA

For product information, sales, service, and technical support:

- In North America, call 1-800-833-9200.
- Worldwide, visit [www.tektronix.com](http://www.tektronix.com) to find contacts in your area.

## Warranty 2

Tektronix warrants that this product will be free from defects in materials and workmanship for a period of one (1) year from the date of shipment. If any such product proves defective during this warranty period, Tektronix, at its option, either will repair the defective product without charge for parts and labor, or will provide a replacement in exchange for the defective product. Batteries are excluded from this warranty. Parts, modules and replacement products used by Tektronix for warranty work may be new or reconditioned to like new performance. All replaced parts, modules and products become the property of Tektronix.

In order to obtain service under this warranty, Customer must notify Tektronix of the defect before the expiration of the warranty period and make suitable arrangements for the performance of service. Customer shall be responsible for packaging and shipping the defective product to the service center designated by Tektronix, shipping charges prepaid, and with a copy of customer proof of purchase. Tektronix shall pay for the return of the product to Customer if the shipment is to a location within the country in which the Tektronix service center is located. Customer shall be responsible for paying all shipping charges, duties, taxes, and any other charges for products returned to any other locations

This warranty shall not apply to any defect, failure or damage caused by improper use or improper or inadequate maintenance and care. Tektronix shall not be obligated to furnish service under this warranty a) to repair damage resulting from attempts by personnel other than Tektronix representatives to install, repair or service the product; b) to repair damage resulting from improper use or connection to incompatible equipment; c) to repair any damage or malfunction caused by the use of non-Tektronix supplies; or d) to service a product that has been modified or integrated with other products when the effect of such modification or integration increases the time or difficulty of servicing the product.

**THIS WARRANTY IS GIVEN BY TEKTRONIX WITH RESPECT TO THE PRODUCT IN LIEU OF ANY OTHER WARRANTIES, EXPRESS OR IMPLIED. TEKTRONIX AND ITS VENDORS DISCLAIM ANY IMPLIED WARRANTIES OF MERCHANTABILITY OR FITNESS FOR A PARTICULAR PURPOSE. TEKTRONIX' S RESPONSIBILITY TO REPAIR OR REPLACE DEFECTIVE PRODUCTS IS THE SOLE AND EXCLUSIVE REMEDY PROVIDED TO THE CUSTOMER FOR BREACH OF THIS WARRANTY. TEKTRONIX AND ITS VENDORS WILL NOT BE LIABLE FOR ANY INDIRECT, SPECIAL, INCIDENTAL, OR CONSEQUENTIAL DAMAGES IRRESPECTIVE OF WHETHER TEKTRONIX OR THE VENDOR HAS ADVANCE NOTICE OF THE POSSIBILITY OF SUCH DAMAGES**



# Table of Contents

<b>General Safety Summary</b> .....	<b>vii</b>
<b>Service Safety Summary</b> .....	<b>ix</b>
<b>Environmental Considerations</b> .....	<b>xi</b>
<b>Preface</b> .....	<b>xiii</b>
Manual Structure .....	xiii
Manual Conventions .....	xiv
Finding Other Information .....	xiv
<b>Introduction</b> .....	<b>xv</b>
Performance Check Interval .....	xv
Strategy for Servicing .....	xv
Tektronix Service Offerings .....	xvi

## Specifications

<b>Product Overview</b> .....	<b>1-1</b>
<b>Specifications</b> .....	<b>1-3</b>
Performance Conditions .....	1-3
Functional Specifications .....	1-3
Electrical Specifications .....	1-4
Mechanical (Physical) Characteristics .....	1-14
Environment Characteristics .....	1-14
Certifications and Compliances .....	1-15

## Theory of Operation

A12 Main Board .....	2-1
A20 PCI Backplane Board .....	2-2
Front-Panel Processor Board .....	2-3
Keypad Board .....	2-4
A40 AC Distributor Board .....	2-4
A100 ASI Interface Module (Option 01) .....	2-4
A110 Universal Parallel/Serial Interface Module (Option 02) .....	2-6
A140 IEEE 1394/ASI Interface Module (Option 05) .....	2-6
A170 SMPTE310M/ASI/PSI Interface Module (Option 07) .....	2-9

## Performance Verification

Equipment Required .....	3-1
MTX100B Test Record .....	3-2
Procedures .....	3-3

## Maintenance

Related Maintenance Procedures .....	4-1
Preparation .....	4-2
Inspection and Cleaning .....	4-3
<b>Removal and Installation Procedures .....</b>	<b>4-7</b>
Preparation .....	4-7
Access Procedure .....	4-14
Procedures for External Modules .....	4-15
Procedure for Board Modules .....	4-21
Procedure for Internal Modules .....	4-26
<b>Verifying the BIOS Configuration .....</b>	<b>4-33</b>
Procedure .....	4-33
<b>Troubleshooting .....</b>	<b>4-35</b>
Troubleshooting Trees .....	4-35
<b>System Software Recovery .....</b>	<b>4-45</b>
Recovery Procedure .....	4-45
<b>Using the Rescue Disc .....</b>	<b>4-47</b>
Recovery Procedure .....	4-47

## Options

Options .....	5-1
---------------	-----

## Diagrams

<b>Diagrams .....</b>	<b>6-1</b>
<b>Diagrams of the Optional Modules .....</b>	<b>6-7</b>
A100 ASI Interface Module (Option 01) .....	6-7
A110 Universal Parallel/Serial Interface Module (Option 02) .....	6-8
A140 IEEE1394/ASI Interface Module (Option 05) .....	6-9
A170 SMPTE310M/ASI/SPI Interface Module (Option 07) .....	6-10

## Replaceable Parts List

Parts Ordering Information .....	7-1
Using the Replaceable Parts List .....	7-3

# List of Figures

<b>Figure 1-1: Timing diagram of the SPI and universal parallel/serial interfaces</b> .....	<b>1-13</b>
<b>Figure 3-1: Equipment connection for verifying the internal clock output level</b> .....	<b>3-4</b>
<b>Figure 3-2: Equipment connection for verifying the internal clock frequency</b> .....	<b>3-5</b>
<b>Figure 3-3: Equipment connection for verifying the SPI interface</b> ..	<b>3-6</b>
<b>Figure 3-4: Equipment connections for verifying the external clock/reference and trigger inputs</b> .....	<b>3-10</b>
<b>Figure 3-5: Equipment connection for verifying the IEEE1394b interface</b> .....	<b>3-13</b>
<b>Figure 3-6: Equipment connection for verifying the output signal-ASI interface</b> .....	<b>3-14</b>
<b>Figure 3-7: Equipment connections for verifying the play operation-ASI interface</b> .....	<b>3-16</b>
<b>Figure 3-8: Equipment connection for verifying the record operation-ASI interface</b> .....	<b>3-17</b>
<b>Figure 3-9: Equipment connection for verifying the recorded file-ASI interface</b> .....	<b>3-19</b>
<b>Figure 3-10: Equipment connection for verifying the output signals-universal parallel/serial interface</b> .....	<b>3-21</b>
<b>Figure 3-11: Equipment connection for verifying the play operation-universal parallel/serial interface</b> .....	<b>3-23</b>
<b>Figure 3-12: Equipment connection for verifying the recorded file-universal parallel/serial interface</b> .....	<b>3-28</b>
<b>Figure 3-13: Equipment connection for verifying the Event output</b>	<b>3-30</b>
<b>Figure 3-14: Equipment connection for verifying the output signal-IEEE1394/ASI interface</b> .....	<b>3-32</b>
<b>Figure 3-15: Equipment connection for verifying the play operation-IEEE1394/ASI interface</b> .....	<b>3-33</b>
<b>Figure 3-16: Equipment connection for verifying the record operation-IEEE1394/ASI interface</b> .....	<b>3-34</b>
<b>Figure 3-17: Equipment connection for verifying the recorded file-IEEE1394/ASI interface</b> .....	<b>3-36</b>
<b>Figure 3-18: Equipment connection for verifying the IEEE1394 output signal</b> .....	<b>3-38</b>
<b>Figure 3-19: Equipment connection for verifying output signal-SMPTE310M interface</b> .....	<b>3-40</b>

<b>Figure 3-20: Equipment connection for verifying the ASI play operation</b> .....	<b>3-42</b>
<b>Figure 3-21: Equipment connection for verifying the ASI record operation</b> .....	<b>3-44</b>
<b>Figure 3-22: Equipment connection for verifying the recorded file-ASI interface</b> .....	<b>3-46</b>
<b>Figure 3-23: Equipment connection for verifying the SMPTE310M play operation</b> .....	<b>3-47</b>
<b>Figure 3-24: Equipment connection for verifying the SMPTE310M record operation</b> .....	<b>3-49</b>
<b>Figure 3-25: Equipment connection for verifying the recorded file-ASI interface</b> .....	<b>3-50</b>
<b>Figure 3-26: Equipment connection for verifying the SPI record operation</b> .....	<b>3-52</b>
<b>Figure 4-1: MTX100B orientation</b> .....	<b>4-10</b>
<b>Figure 4-2: External modules</b> .....	<b>4-11</b>
<b>Figure 4-3: Board modules</b> .....	<b>4-12</b>
<b>Figure 4-4: Internal modules</b> .....	<b>4-13</b>
<b>Figure 4-5: Guide to removal procedures</b> .....	<b>4-14</b>
<b>Figure 4-6: Cabinet removal</b> .....	<b>4-16</b>
<b>Figure 4-7: Right-side and left-side covers removal</b> .....	<b>4-17</b>
<b>Figure 4-8: Front-panel unit removal</b> .....	<b>4-18</b>
<b>Figure 4-9: Disassembly of front-panel assembly</b> .....	<b>4-20</b>
<b>Figure 4-10: Interface module, A12 Main board, CPU board, and A20 PCI Backplane board removal</b> .....	<b>4-22</b>
<b>Figure 4-11: Hard disk drive removal</b> .....	<b>4-27</b>
<b>Figure 4-12: Internal and external fan removal</b> .....	<b>4-29</b>
<b>Figure 4-13: 12 V main power supply and A40 AC Distributor board removal</b> .....	<b>4-31</b>
<b>Figure 4-14: RFI filter removal</b> .....	<b>4-32</b>
<b>Figure 4-15: Troubleshooting procedure (1)</b> .....	<b>4-36</b>
<b>Figure 4-16: Troubleshooting procedure (2)</b> .....	<b>4-37</b>
<b>Figure 4-17: Troubleshooting procedure (3)</b> .....	<b>4-38</b>
<b>Figure 4-18: Troubleshooting procedure (4)</b> .....	<b>4-39</b>
<b>Figure 4-19: Troubleshooting procedure (5)</b> .....	<b>4-40</b>
<b>Figure 4-20: Troubleshooting procedure (6)</b> .....	<b>4-41</b>
<b>Figure 4-21: Troubleshooting procedure (7)</b> .....	<b>4-42</b>
<b>Figure 4-22: A20 PCI Backplane board view-back side</b> .....	<b>4-42</b>
<b>Figure 4-23: A20 PCI Backplane board view-right side</b> .....	<b>4-43</b>



---

<b>Figure 6-1: MTX100B block diagram</b> .....	<b>6-3</b>
<b>Figure 6-2: MTX100B interconnect diagram</b> .....	<b>6-5</b>
<b>Figure 6-3: A100 ASI Interface module connections</b> .....	<b>6-7</b>
<b>Figure 6-4: A110 Universal Parallel/Serial Interface module connections</b> .....	<b>6-8</b>
<b>Figure 6-5: A140 IEEE1394/ASI Interface module connections</b> ....	<b>6-9</b>
<b>Figure 6-6: A170 SMPTE310M/ASI/SPI Interface module connections</b> .....	<b>6-10</b>
<b>Figure 7-1: Cabinet and covers</b> .....	<b>7-5</b>
<b>Figure 7-2: Internal modules (1)</b> .....	<b>7-7</b>
<b>Figure 7-3: Internal modules (2)</b> .....	<b>7-9</b>
<b>Figure 7-4: Front-panel unit</b> .....	<b>7-11</b>
<b>Figure 7-5: Cables</b> .....	<b>7-13</b>

## List of Tables

<b>Table 1-1: Functional specifications</b> .....	<b>1-3</b>
<b>Table 1-2: Mainframe</b> .....	<b>1-4</b>
<b>Table 1-3: ASI interface (Option 01)</b> .....	<b>1-8</b>
<b>Table 1-4: Universal parallel/serial interface (Option 02)</b> .....	<b>1-8</b>
<b>Table 1-5: IEEE1394/ASI interface (Option 05)</b> .....	<b>1-11</b>
<b>Table 1-6: SMPTE310M/ASI/SPI interface (Option 07)</b> .....	<b>1-11</b>
<b>Table 1-7: Mechanical characteristics</b> .....	<b>1-14</b>
<b>Table 1-8: Environmental characteristics</b> .....	<b>1-14</b>
<b>Table 1-9: Certifications and compliances</b> .....	<b>1-15</b>
<b>Table 3-1: Equipment required for performance verification</b> .....	<b>3-1</b>
<b>Table 3-2: MTX100B test record</b> .....	<b>3-2</b>
<b>Table 3-3: Output level of each connector pin</b> .....	<b>3-22</b>
<b>Table 4-1: External inspection check list</b> .....	<b>4-4</b>
<b>Table 4-2: Internal inspection check list</b> .....	<b>4-5</b>
<b>Table 4-3: Summary of procedures</b> .....	<b>4-8</b>
<b>Table 4-4: Tools required for module removal</b> .....	<b>4-9</b>

# General Safety Summary

Review the following safety precautions to avoid injury and prevent damage to this product or any products connected to it. To avoid potential hazards, use this product only as specified.

*Only qualified personnel should perform service procedures.*

## **To Avoid Fire or Personal Injury**

**Use Proper Power Cord.** Use only the power cord specified for this product and certified for the country of use.

**Ground the Product.** This product is grounded through the grounding conductor of the power cord. To avoid electric shock, the grounding conductor must be connected to earth ground. Before making connections to the input or output terminals of the product, ensure that the product is properly grounded.

**Observe All Terminal Ratings.** To avoid fire or shock hazard, observe all ratings and markings on the product. Consult the product manual for further ratings information before making connections to the product.

**Do Not Operate Without Covers.** Do not operate this product with covers or panels removed.

**Use Proper Fuse.** Use only the fuse type and rating specified for this product.

**Avoid Exposed Circuitry.** Do not touch exposed connections and components when power is present.

**Do Not Operate With Suspected Failures.** If you suspect there is damage to this product, have it inspected by qualified service personnel.

**Do Not Operate in Wet/Damp Conditions.**

**Do Not Operate in an Explosive Atmosphere.**

**Keep Product Surfaces Clean and Dry.**

**Provide Proper Ventilation.** Refer to the manual's installation instructions for details on installing the product so it has proper ventilation.

**Symbols and Terms**

**Terms in this Manual.** These terms may appear in this manual:



---

**WARNING.** *Warning statements identify conditions or practices that could result in injury or loss of life.*

---



---

**CAUTION.** *Caution statements identify conditions or practices that could result in damage to this product or other property.*

---

**Terms on the Product.** These terms may appear on the product:

DANGER indicates an injury hazard immediately accessible as you read the marking.

WARNING indicates an injury hazard not immediately accessible as you read the marking.

CAUTION indicates a hazard to property including the product.

**Symbols on the Product.** The following symbols may appear on the product:



# Service Safety Summary

Only qualified personnel should perform service procedures. Read this *Service Safety Summary* and the *General Safety Summary* before performing any service procedures.

**Do Not Service Alone.** Do not perform internal service or adjustments of this product unless another person capable of rendering first aid and resuscitation is present.

**Disconnect Power.** To avoid electric shock, disconnect the mains power by means of the power cord or, if provided, the power switch.

**Use Care When Servicing With Power On.** Dangerous voltages or currents may exist in this product. Disconnect power, remove battery (if applicable), and disconnect test leads before removing protective panels, soldering, or replacing components.

To avoid electric shock, do not touch exposed connections.



# Environmental Considerations

This section provides information about the environmental impact of the product.

## Product End-of-Life Handling

Observe the following guidelines when recycling an instrument or component:

**Equipment Recycling.** Production of this equipment required the extraction and use of natural resources. The equipment may contain substances that could be harmful to the environment or human health if improperly handled at the product's end of life. In order to avoid release of such substances into the environment and to reduce the use of natural resources, we encourage you to recycle this product in an appropriate system that will ensure that most of the materials are reused or recycled appropriately.



The symbol shown to the left indicates that this product complies with the European Union's requirements according to Directive 2002/96/EC on waste electrical and electronic equipment (WEEE). For information about recycling options, check the Support/Service section of the Tektronix Web site ([www.tektronix.com](http://www.tektronix.com)).

**Mercury Notification.** This product uses an LCD backlight lamp that contains mercury. Disposal may be regulated due to environmental considerations. Please contact your local authorities or, within the United States, the Electronics Industries Alliance ([www.eiae.org](http://www.eiae.org)) for disposal or recycling information.

## Restriction of Hazardous Substances

This product has been classified as Monitoring and Control equipment, and is outside the scope of the 2002/95/EC RoHS Directive. This product is known to contain lead, cadmium, mercury, and hexavalent chromium.





# Preface

This is the service manual for the MTX100B MPEG Recorder & Player. This manual contains information needed to service an MTX100B to the module level.

## Manual Structure

This manual is divided into sections, such as *Specifications* and *Theory of Operation*. Further, some sections are divided into subsections, such as *Product Description* and *Removal and Installation Procedures*.

Sections containing procedures also contain introductions to those procedures. Be sure to read these introductions because they provide information needed to do the service correctly and efficiently. The following are brief descriptions of each manual section.

- *Specifications* contains a description of the MTX100B and the characteristics that apply to it.
- *Theory of Operation* contains circuit descriptions that support service to the module level.
- *Performance Verification* contains procedures for confirming that an MTX100B functions properly and meets warranted characteristics.
- *Maintenance* contains information and procedures for performing preventive and corrective maintenance of an MTX100B. These instructions include cleaning, module removal and installation, and fault isolation to the module level.
- *Options* contains descriptions of factory-installed options and field-upgradable options.
- *Diagrams* contains the block diagrams and interconnection diagrams of the MTX100B and the optional interface modules.
- *Replaceable Parts List* includes a table of all replaceable modules, their descriptions, and their Tektronix part numbers.

## Manual Conventions

This manual uses certain conventions with which you should become familiar.

Some sections of the manual contain procedures for you to perform. To keep those instructions clear and consistent, this manual uses the following conventions:

- Names of front panel controls and menus appear in the same case (initial capitals, all uppercase, and so forth) in the manual as is used on the MTX100B front panel and menus.
- Instruction steps are numbered unless there is only one step.
- **Bold** text refers to specific interface elements that you are instructed to select, click, or clear.

Example: Press the **Menu** button to open the **File** menu.

- *Italic* text refers to document names or sections. Italics are also used in NOTES, CAUTIONS, and WARNINGS.

Example: The *Diagrams* section, beginning on page 6-1, includes a block diagram and an interconnect diagram.

**Modules** Throughout this manual, any replaceable component, assembly, or part of the MTX100B is referred to generically as a module. In general, a module is an assembly (like a circuit board), rather than a component (like a resistor or an integrated circuit). Sometimes a single component is a module. For example, the chassis of the MTX100B is a module.

**Safety** Symbols and terms related to safety appear in the *General Safety Summary* and *Service Safety Summary* near the beginning of this manual.

## Finding Other Information

Other documentation for the MTX100B includes:

- The *MTX100B MPEG Recorder & Player User Manual* contains a tutorial to quickly describe how to operate the MTX100B. It also includes an in-depth discussion on how to more completely use the MTX100B features.

# Introduction

This manual contains information needed to properly service the MTX100B MPEG Recorder & Player, as well as general information critical to safe and effective servicing.

To prevent personal injury or damage to the MTX100B, consider the following before attempting service:

- The procedures in this manual should be performed only by a qualified service person.
- Read the *General Safety Summary* and the *Service Safety Summary*, beginning on page vii.

When using this manual for servicing be sure to follow all warnings, cautions, and notes.

## Performance Check Interval

Generally, the performance check described in section 3, *Performance Verification*, should be done every 12 months. In addition, a performance check is recommended after module replacement.

If the MTX100B does not meet performance criteria, repair is necessary.

## Strategy for Servicing

Throughout this manual, the term “module” refers to any field-replaceable component, assembly, or part of the MTX100B.

This manual contains all the information needed for periodic maintenance of the MTX100B (examples of such information are procedures for checking performance).

Further, this manual contains all information for corrective maintenance down to the module level. To isolate a failure to a module, use the fault isolation procedures found in *Troubleshooting*, part of section 4, *Maintenance*. To remove and replace any failed module, follow the instructions in *Removal and Installation Procedures*, also part of section 4. After isolating a faulty module, replace it with a fully-tested module obtained from the factory. Section 7, *Replaceable Parts List*, contains part number and ordering information for all replaceable modules.

## Tektronix Service Offerings

Tektronix provides service to cover repair under warranty as well as other services that may provide a cost-effective answer to your service needs.

Whether providing warranty repair service or any of the other services listed below, Tektronix service technicians are well trained to service the MTX100B. They have access to the latest information on improvements to the MTX100B as well as the latest new options.

### Warranty Repair Service

Tektronix warrants this product for one year from date of purchase. The warranty appears after the title page in this manual. Tektronix technicians provide warranty service at most Tektronix service locations. The Tektronix product catalog lists all worldwide service locations or you can visit our Web site for service information: [www.tektronix.com](http://www.tektronix.com).

### Self Service

Tektronix supports repair to the module level by providing Module Exchange.

**Module Exchange.** This service reduces down-time for repair by allowing you to exchange most modules for remanufactured ones. Each module comes with a 90-day service warranty.

**For More Information.** Contact your local Tektronix service center or sales engineer for more information on any of the repair or adjustment services just described.



# Specifications



# Product Overview

The MTX100B MPEG Recorder & Player records and plays MPEG-2 transport streams that are compliant with ATSC, DVB, and ARIB standards.

The MTX100B provides the following features:

- Data rate: 200 Mbps maximum (RAM mode); 256 Kbps minimum
- Hierarchy display of the stored or captured transport stream
- 188, 204, 208 bytes packet size, S-TMCC, M-TMCC, non transport stream, and partial transport stream output formats
- Real-time updating of transport stream parameters; continuity\_counter, PCR/PTS/DTS, TOT/TDT/STT, NPT, and Reed Solomon (ISDB-T transport stream only)
- Continuous recording of captured streams
- PCR jitter insertion
- Triggered stream capture
- Full remote control using Ethernet interface
- Scheduler application for automated stream playout and record (Option SC only)
- Optional ASI, universal parallel/serial, IEEE1394/ASI, and SMPTE310M/ASI/SPI interfaces available

The MTX100B includes the ReMux application software that provides the capability to create a transport stream of super frame structure defined in the ISDB-S systems from an MPEG2 transport stream.





# Specifications

Tables 1-1 through 1-8 list the functional, electrical, mechanical, and environmental characteristics of the MTX100B. Table 1-9 lists the national and international standards to which the MTX100B complies.

All listed specifications are guaranteed unless labeled “typical”. Typical specifications are provided for your convenience but are not guaranteed.

## Performance Conditions

The electrical characteristics listed on the following pages are valid under the following conditions:

- The MTX100B must be in an environment where the temperature, altitude, humidity, and vibration conditions are within the operating limits described in Table 1-8 on page 1-14.
- The MTX100B must have a warm-up period of at least 20 minutes.
- The MTX100B must be operating at an ambient temperature between +5 °C to +40 °C, unless otherwise noted.

## Functional Specifications

**Table 1-1: Functional specifications**

Characteristics	Description
System configuration	
System OS	Windows XP Professional
CPU	1.3 GHz
System memory	1 GB
Display	6.3 inch, XGA (1024 x 768), Windows Control Panel setting is SVGA (800 x 600)
Hard disk drive	160 GB
Expansion slot	1 - PCI slot

## Electrical Specifications

**Table 1-2: Mainframe**

Characteristics	Description
Maximum output rate	
Hard disk	≥ 120 Mbps
RAM	≥ 200 Mbps
Maximum record rate	
Hard disk	≥ 120 Mbps (File size: < 4 GB, just after disk format operation) ≥ 90 Mbps (File size: 33 GB, just after disk format operation)
RAM	≥ 200 Mbps
Internal reference clock	For Output_clock, PCR/PTS/DTS, packet operation timing, and TDT/STT time.
Reference clock	27 MHz ± 1 ppm
External reference/clock input	
Connector type	BNC
Input impedance, typical	50 Ω
Reference input	
Frequency	8.129698 MHz, 10 MHz, 27 MHz
Input level, typical	Sine wave: 0 ± 6 dBm Square wave: 0.5 Vp-p to 3.0 Vp-p
Clock input	
Frequency	160 kHz to 25 MHz (parallel clock) 1.28 MHz to 32 MHz (serial clock)
Input level, typical	0.5 V to 3.0 V
External trigger input/MISC output	
Connector type	BNC
Input impedance, typical	1 kΩ
Threshold level	Rising and falling edges are programmable.
High level	> 3.5 V (maximum input voltage: 7 V)
Low level	< 0.8 V
Output level	
High level	> 2.2 V (with 50 Ω termination)
Low level	< 0.8 V (with 50 Ω termination)
Output impedance	50 Ω

Table 1-2: Mainframe (Cont.)

Characteristics	Description																						
PLL																							
Frequency	50 MHz to 100 MHz, Locked to reference clock																						
Output clock	50 MHz maximum (serial clock) 26.75 MHz maximum (parallel clock)																						
Output rate	214 Mbps maximum 64 Kbps minimum																						
TS clock	$TS\ clock = (X / (2 * Y * Z)) * 27\ MHz$																						
(Internal and external reference, 27 MHz and 10 MHz)	$15362 < X < 31248$ $1686 < Y < 3376$ $2 \leq Z \leq 65536$																						
(External parallel clock)	$TS\ clock = (X / (2 * Y * Z)) * \text{external parallel clock}, 214\ MHz\ maximum$  $15632 < X < 31248$ $1 < Y < 16383$ $2 \leq Z \leq 65536$																						
(External serial clock)	$TS\ clock = (X / (2 * Y * Z)) * \text{external serial clock} / 8,32\ MHz\ maximum$  $15632 < X < 31248$ $1 < Y < 16383$ $2 \leq Z \leq 65536$																						
P/N and Jitter (serial clock)	$< -104\ dBc/Hz\ at\ 21.455707\ MHz\ +20\ kHz\ (RBW=300\ Hz)$																						
SPI interface																							
Connector type	D-sub, 25 pin																						
Data rate	256 Kbps to 214 Mbps																						
Pin assignments	<table> <tr><td>1</td><td>DCLK</td></tr> <tr><td>2</td><td>GND</td></tr> <tr><td>3 to 10</td><td>DATA 7 to DATA 0</td></tr> <tr><td>11</td><td>DVALID</td></tr> <tr><td>12</td><td>PSYNC</td></tr> <tr><td>13</td><td>Shield</td></tr> <tr><td>14</td><td><u>DCLK</u></td></tr> <tr><td>15</td><td>GND</td></tr> <tr><td>16 to 23</td><td><u>DATA 7</u> to <u>DATA 0</u></td></tr> <tr><td>24</td><td><u>DVALID</u></td></tr> <tr><td>25</td><td><u>PSYNC</u></td></tr> </table>	1	DCLK	2	GND	3 to 10	DATA 7 to DATA 0	11	DVALID	12	PSYNC	13	Shield	14	<u>DCLK</u>	15	GND	16 to 23	<u>DATA 7</u> to <u>DATA 0</u>	24	<u>DVALID</u>	25	<u>PSYNC</u>
1	DCLK																						
2	GND																						
3 to 10	DATA 7 to DATA 0																						
11	DVALID																						
12	PSYNC																						
13	Shield																						
14	<u>DCLK</u>																						
15	GND																						
16 to 23	<u>DATA 7</u> to <u>DATA 0</u>																						
24	<u>DVALID</u>																						
25	<u>PSYNC</u>																						
Output																							
Output level, typical	330 mV to 550 mV (termination: internal 100 Ω. external 100 Ω), bus LVDS with 50 Ω termination																						
Offset	1.1 V to 1.5 V																						
Output resistance, typical	100 Ω, between differential outputs (output off)																						

**Table 1-2: Mainframe (Cont.)**

Characteristics	Description																																																				
Data delay, typical	± 5 ns from the falling edge of DCLK (see Figure 1-1.)																																																				
Input																																																					
Input level, typical	> +100 mV, < -100 mV, (RI+)-(RI-) with 100 Ω termination																																																				
Input resistance, typical	100 Ω (between differential inputs)																																																				
Clock pulse width, typical	T/2 ± T/10, T=1/f (f=byte clock frequency) (see Figure 1-1.)																																																				
Data hold time, typical	T/2 ± T/10, T=1/f (f=byte clock frequency, Data are latched on DCLK rising edge) (see Figure 1-1.)																																																				
VGA output																																																					
Connector type	D-sub, 15 pin																																																				
Pin assignments	<table border="0"> <tr><td>1</td><td>RED</td><td>9</td><td>NC</td></tr> <tr><td>2</td><td>GREEN</td><td>10</td><td>GND</td></tr> <tr><td>3</td><td>BLUE</td><td>11</td><td>NC</td></tr> <tr><td>4</td><td>NC</td><td>12</td><td>NC</td></tr> <tr><td>5</td><td>GND</td><td>13</td><td>HSYNC</td></tr> <tr><td>6</td><td>GND</td><td>14</td><td>VSYNC</td></tr> <tr><td>7</td><td>GND</td><td>15</td><td>NC</td></tr> <tr><td>8</td><td>GND</td><td></td><td></td></tr> </table>	1	RED	9	NC	2	GREEN	10	GND	3	BLUE	11	NC	4	NC	12	NC	5	GND	13	HSYNC	6	GND	14	VSYNC	7	GND	15	NC	8	GND																						
1	RED	9	NC																																																		
2	GREEN	10	GND																																																		
3	BLUE	11	NC																																																		
4	NC	12	NC																																																		
5	GND	13	HSYNC																																																		
6	GND	14	VSYNC																																																		
7	GND	15	NC																																																		
8	GND																																																				
Printer port	Supports SPP (Standard Parallel Port), EPP (Enhanced Parallel Port ), and ECP (Extended Capabilities Port) modes.																																																				
Connector type	D-sub, 25 pin																																																				
Pin assignments	<table border="0"> <tr><td>1</td><td>STROBE</td><td>14</td><td>AUTOLF</td></tr> <tr><td>2</td><td>D0</td><td>15</td><td>ERR</td></tr> <tr><td>3</td><td>D1</td><td>16</td><td>INIT</td></tr> <tr><td>4</td><td>D2</td><td>17</td><td>SELECT</td></tr> <tr><td>5</td><td>D3</td><td>18</td><td>GND</td></tr> <tr><td>6</td><td>D4</td><td>19</td><td>GND</td></tr> <tr><td>7</td><td>D5</td><td>20</td><td>GND</td></tr> <tr><td>8</td><td>D6</td><td>21</td><td>GND</td></tr> <tr><td>9</td><td>D7</td><td>22</td><td>GND</td></tr> <tr><td>10</td><td>ACK</td><td>23</td><td>GND</td></tr> <tr><td>11</td><td>BUSY</td><td>24</td><td>GND</td></tr> <tr><td>12</td><td>Paper Empty</td><td>25</td><td>GND</td></tr> <tr><td>13</td><td>SELECT</td><td></td><td></td></tr> </table>	1	STROBE	14	AUTOLF	2	D0	15	ERR	3	D1	16	INIT	4	D2	17	SELECT	5	D3	18	GND	6	D4	19	GND	7	D5	20	GND	8	D6	21	GND	9	D7	22	GND	10	ACK	23	GND	11	BUSY	24	GND	12	Paper Empty	25	GND	13	SELECT		
1	STROBE	14	AUTOLF																																																		
2	D0	15	ERR																																																		
3	D1	16	INIT																																																		
4	D2	17	SELECT																																																		
5	D3	18	GND																																																		
6	D4	19	GND																																																		
7	D5	20	GND																																																		
8	D6	21	GND																																																		
9	D7	22	GND																																																		
10	ACK	23	GND																																																		
11	BUSY	24	GND																																																		
12	Paper Empty	25	GND																																																		
13	SELECT																																																				
USB 2.0 interface																																																					
Number of connectors	2																																																				
Pin assignments	<table border="0"> <tr><td>1</td><td>VCC</td></tr> <tr><td>2</td><td>-DATA</td></tr> <tr><td>3</td><td>+DATA</td></tr> <tr><td>4</td><td>GND</td></tr> </table>	1	VCC	2	-DATA	3	+DATA	4	GND																																												
1	VCC																																																				
2	-DATA																																																				
3	+DATA																																																				
4	GND																																																				

**Table 1-2: Mainframe (Cont.)**

<b>Characteristics</b>	<b>Description</b>																				
LAN interface	10/100/1000 Base-T Ethernet interface																				
Connector type	RJ45																				
Pin assignments	<table> <tr> <td>1</td> <td>MDI_0+</td> <td>5</td> <td>MDI_2-</td> </tr> <tr> <td>2</td> <td>MDI_0-</td> <td>6</td> <td>MDI_1-</td> </tr> <tr> <td>3</td> <td>MDI_1+</td> <td>7</td> <td>MDI_3+</td> </tr> <tr> <td>4</td> <td>MDI_2+</td> <td>8</td> <td>MDI_3-</td> </tr> </table>	1	MDI_0+	5	MDI_2-	2	MDI_0-	6	MDI_1-	3	MDI_1+	7	MDI_3+	4	MDI_2+	8	MDI_3-				
1	MDI_0+	5	MDI_2-																		
2	MDI_0-	6	MDI_1-																		
3	MDI_1+	7	MDI_3+																		
4	MDI_2+	8	MDI_3-																		
Serial interface (Com)	RS-232C																				
Connector type	D-sub, 9 pin																				
Pin assignments	<table> <tr> <td>1</td> <td>DCD</td> <td>6</td> <td>DSR</td> </tr> <tr> <td>2</td> <td>RX</td> <td>7</td> <td>RTS</td> </tr> <tr> <td>3</td> <td>TX</td> <td>8</td> <td>CTS</td> </tr> <tr> <td>4</td> <td>DTR</td> <td>9</td> <td>RI</td> </tr> <tr> <td>5</td> <td>GND</td> <td></td> <td></td> </tr> </table>	1	DCD	6	DSR	2	RX	7	RTS	3	TX	8	CTS	4	DTR	9	RI	5	GND		
1	DCD	6	DSR																		
2	RX	7	RTS																		
3	TX	8	CTS																		
4	DTR	9	RI																		
5	GND																				
IEEE1394B interface																					
Compliant	IEEE1394B-2002																				
Pin assignments	<table> <tr> <td>1</td> <td>TPB-</td> <td>6</td> <td>VG</td> </tr> <tr> <td>2</td> <td>TPB+</td> <td>7</td> <td>NC</td> </tr> <tr> <td>3</td> <td>TPA-</td> <td>8</td> <td>VP</td> </tr> <tr> <td>4</td> <td>TPA+</td> <td>9</td> <td>TPB (R)</td> </tr> <tr> <td>5</td> <td>TPA (R)</td> <td></td> <td></td> </tr> </table>	1	TPB-	6	VG	2	TPB+	7	NC	3	TPA-	8	VP	4	TPA+	9	TPB (R)	5	TPA (R)		
1	TPB-	6	VG																		
2	TPB+	7	NC																		
3	TPA-	8	VP																		
4	TPA+	9	TPB (R)																		
5	TPA (R)																				
AC line power																					
Rating Voltage	100 VAC to 240 VAC, CAT II																				
Voltage Range	90 VAC to 250 VAC																				
Frequency Range	50 Hz to 60 Hz																				
Maximum power	180 VA																				
Maximum current	1.3 A																				
Main fuse data	5 A Time-delayed, 250 V (not operator replaceable) 2 A Time-delayed, 250 V (not operator replaceable)																				

**Table 1-3: ASI interface (Option 01)**

Characteristics	Description
Standard conformance	EN50083-9 Annex B
Connector type	BNC
Impedance, typical	75 $\Omega$
Data rate	256 Kbps to 214 Mbps
Output	
Number of outputs	2
Output voltage	800 mV $\pm$ 10%
Jitter	$\leq$ 0.2 UI (p-p)
Rise/fall time (20% to 80%)	$\leq$ 1.2 ns
Return loss	< -17 dB ( 5 MHz to 270 MHz) into 75 $\Omega$ load
Input	
Number of inputs	1 (with active loop-through output)
Input voltage	200 mV to 800 mV
Return loss	< -17 dB ( 5 MHz to 270 MHz) into 75 $\Omega$ load
Data format	Accepts both burst and packet modes ASI

**Table 1-4: Universal parallel/serial interface (Option 02)**

Characteristics	Description																						
Parallel interface mode																							
Connector type	D-sub, 25 pin (the same connector as serial output)																						
Data rate	256 Kbps to 214 Mbps																						
Pin assignments	<table border="0"> <tr><td>1</td><td>DCLK</td></tr> <tr><td>2</td><td>GND</td></tr> <tr><td>3 to 10</td><td>DATA 7 to DATA 0</td></tr> <tr><td>11</td><td>DVALID</td></tr> <tr><td>12</td><td>PSYNC</td></tr> <tr><td>13</td><td>Shield</td></tr> <tr><td>14</td><td>DCLK</td></tr> <tr><td>15</td><td>GND</td></tr> <tr><td>16 to 23</td><td><math>\overline{\text{DATA 7}}</math> to <math>\overline{\text{DATA 0}}</math></td></tr> <tr><td>24</td><td><math>\overline{\text{DVALID}}</math></td></tr> <tr><td>25</td><td><math>\overline{\text{PSYNC}}</math></td></tr> </table>	1	DCLK	2	GND	3 to 10	DATA 7 to DATA 0	11	DVALID	12	PSYNC	13	Shield	14	DCLK	15	GND	16 to 23	$\overline{\text{DATA 7}}$ to $\overline{\text{DATA 0}}$	24	$\overline{\text{DVALID}}$	25	$\overline{\text{PSYNC}}$
1	DCLK																						
2	GND																						
3 to 10	DATA 7 to DATA 0																						
11	DVALID																						
12	PSYNC																						
13	Shield																						
14	DCLK																						
15	GND																						
16 to 23	$\overline{\text{DATA 7}}$ to $\overline{\text{DATA 0}}$																						
24	$\overline{\text{DVALID}}$																						
25	$\overline{\text{PSYNC}}$																						

**Table 1-4: Universal parallel/serial interface (Option 02) (Cont.)**

Characteristics	Description																										
Output level, typical	Note: Do not connect the $\overline{\text{Asserted Low}}$ pins for single-end use.																										
TTL without termination	LO: 0 V HI: 3.3 V																										
LVDS without termination	0.66 Vp-p to 1.1 Vp-p (amplitude) 1.1 V to 1.5 V (offset)																										
ECL without termination	LO: -2.1 V HI: -0.5 V																										
Output impedance, typical	50 $\Omega$ $\pm$ 5% (per pin, single-end)																										
Output resistance, typical	$\geq$ 1 k $\Omega$ (when the output is off, per pin, single-end)																										
Data delay, typical	0 $\pm$ 5 ns from the falling edge of DCLK (see Figure 1-1 on page 1-13)																										
Single-end input level, typical																											
TTL with termination	LO: 0.0 V to 0.5 V HI: 1.2 V to 5.0 V																										
ECL with termination	LO: -5.2 V to -1.05 V HI: -0.25 V to 0.0 V																										
Differential input level, typical	0.4 V to 1.0 Vp-p (between +pin and -pin without termination) 0.2 V to 1.0 Vp-p (between +pin and -pin with termination)																										
Input resistance, typical	50 $\Omega$ $\pm$ 5% to GND pin (single end termination: ON) 110 $\Omega$ $\pm$ 5% (differential termination: ON) $\geq$ 1 k $\Omega$ to GND (termination: OFF)																										
Clock pulse width, typical	T/2 $\pm$ T/10, T=1/f (f=byte clock frequency) (see Figure 1-1 on page 1-13)																										
Data hold time, typical	T/2 $\pm$ T/10, T=1/f (f=byte clock frequency, data are latched on DCLK rising edge) (see Figure 1-1 on page 1-13)																										
Serial interface mode																											
Connector type	D-sub, 25 pin (uses a common connector with parallel interface)																										
Data rate	256 Kbps to 40 Mbps																										
Pin Assignments	<table> <tbody> <tr><td>1</td><td>DCLK</td></tr> <tr><td>2</td><td>GND</td></tr> <tr><td>3 to 9</td><td>Not managed</td></tr> <tr><td>10</td><td>DATA 0</td></tr> <tr><td>11</td><td>DVALID</td></tr> <tr><td>12</td><td>PSYNC</td></tr> <tr><td>13</td><td>Shield</td></tr> <tr><td>14</td><td><math>\overline{\text{DCLK}}</math></td></tr> <tr><td>15</td><td>GND</td></tr> <tr><td>16 to 22</td><td>Not managed</td></tr> <tr><td>23</td><td><math>\overline{\text{DATA 0}}</math></td></tr> <tr><td>24</td><td><math>\overline{\text{DVALID}}</math></td></tr> <tr><td>25</td><td>PSYNC</td></tr> </tbody> </table>	1	DCLK	2	GND	3 to 9	Not managed	10	DATA 0	11	DVALID	12	PSYNC	13	Shield	14	$\overline{\text{DCLK}}$	15	GND	16 to 22	Not managed	23	$\overline{\text{DATA 0}}$	24	$\overline{\text{DVALID}}$	25	PSYNC
1	DCLK																										
2	GND																										
3 to 9	Not managed																										
10	DATA 0																										
11	DVALID																										
12	PSYNC																										
13	Shield																										
14	$\overline{\text{DCLK}}$																										
15	GND																										
16 to 22	Not managed																										
23	$\overline{\text{DATA 0}}$																										
24	$\overline{\text{DVALID}}$																										
25	PSYNC																										

**Table 1-4: Universal parallel/serial interface (Option 02) (Cont.)**

Characteristics	Description
Output level, typical	Note: Do not connect the Asserted Low pins for single-end use.
TTL without termination	LO: 0 V HI: 3.3 V
LVDS without termination	0.66 Vp-p to 1.1 Vp-p (amplitude) 1.1 V to 1.5 V (offset)
ECL without termination	LO: -2.1 V HI: -0.5 V
Output impedance, typical	50 $\Omega$ $\pm$ 5% (per pin, single-end)
Output resistance, typical	$\geq$ 1 k $\Omega$ (when the output is off, per pin, single-end)
Data delay, typical	0 $\pm$ 5 ns from the falling edge of DCLK (see Figure 1-1 on page 1-13)
Single-end input level, typical	
TTL with termination	LO: 0.0 V to 0.5 V HI: 1.2 V to 5.0 V
ECL with termination	LO: -5.2 V to -1.05 V HI: -0.25 V to 0.0 V
Differential input level, typical	0.4 V to 1.0 Vp-p (between +pin and -pin without termination) 0.2 V to 1.0 Vp-p (between +pin and -pin with termination)
Input resistance, typical	50 $\Omega$ $\pm$ 5% to GND pin (single end termination: On) 110 $\Omega$ $\pm$ 5% (differential termination: On) $\geq$ 1 k $\Omega$ to GND pin (termination: Off)
Clock pulse width, typical	$T/2 \pm T/10$ , $T=1/f$ (f=byte clock frequency) (see Figure 1-1 on page 1-13)
Data hold time, typical	$T/2 \pm T/10$ , $T=1/f$ (f=byte clock frequency, data are latched on DCLK rising edge.) (see Figure 1-1 on page 1-13)
Event output (EVENT OUT)	
Connector type	BNC
Output level, typical	TTL without termination  LO: < 0.4 V HI: > 2.4 V
Output impedance, typical	50 $\Omega$



**Table 1-5: IEEE1394/ASI interface (Option 05)**

Characteristics	Description
IEEE1394 interface	
Standard conformance	IEEE Std 1394-1995 IEEE Standard for High Performance serial Bus
Number of connectors	2
Serial interface rate	S-400
Maximum TS rate	40 Mbps
ASI interface	
Standard conformance	EN 50083-9 Annex B
Connector type	BNC
Impedance, typical	75 $\Omega$
Data rate	256 Kbps to 214 Mbps
Input voltage, typical	200 mV to 800 mV
Output voltage	800 mV $\pm$ 10%
Return loss	< -17 dB (5 MHz to 270 MHz) into 75 $\Omega$ load

**Table 1-6: SMPTE310M/ASI/SPI interface (Option 07)**

Characteristics	Description
SMPTE310M interface	Uses common input/output connectors with the ASI interface.
Standard conformance	SMPTE310M
Connector type	BNC
Impedance	75 $\Omega$
Data rate	19.392658 Mbps (8 VSB, 188 bytes packet size)
Output	
Number of outputs	1
Output voltage	800 mV $\pm$ 10%
Jitter	$\leq$ 0.2 UI p-p
Rise/fall time	0.4 ns to 5.0 ns (20% to 80%)
Frequency range, typical	$\pm$ 3%
Input	
Number of inputs	1
Input voltage, typical	800 mV $\pm$ 10%
Frequency range, typical	$\pm$ 3%

**Table 1-6: SMPTE310M/ASI/SPI interface (Option 07) (Cont.)**

Characteristics	Description																						
ASI interface	Uses common input/output connectors with the SMPTE310M interface.																						
Standard conformance	EN 50083-9 Annex B																						
Connector type	BNC																						
Impedance	75 $\Omega$																						
Data rate	256 Kbps to 214 Mbps																						
Output																							
Number of outputs	1																						
Output voltage	800 mV $\pm$ 10%																						
Jitter	$\leq$ 0.2 UI p-p																						
Rise/fall time	$\leq$ 1.2 ns (20% to 80%)																						
Return loss	< -17 dB ( 5 MHz to 270 MHz) into 75 $\Omega$ load																						
Input																							
Number of inputs	1																						
Input voltage, typical	200 mV to 800 mV																						
Return loss	< -17 dB ( 5 MHz to 270 MHz) into 75 $\Omega$ load																						
SPI interface																							
Connector type	D-sub, 25 pin																						
Data rate	256 Kbps to 214 Mbps																						
Pin assignments	<table border="0"> <tr><td>1</td><td>DCLK</td></tr> <tr><td>2</td><td>GND</td></tr> <tr><td>3 to 10</td><td>DATA 7 to DATA 0</td></tr> <tr><td>11</td><td>DVALID</td></tr> <tr><td>12</td><td>PSYNC</td></tr> <tr><td>13</td><td>Shield</td></tr> <tr><td>14</td><td>DCLK</td></tr> <tr><td>15</td><td>GND</td></tr> <tr><td>16 to 23</td><td><u>DATA 7</u> to <u>DATA 0</u></td></tr> <tr><td>24</td><td><u>DVALID</u></td></tr> <tr><td>25</td><td><u>PSYNC</u></td></tr> </table>	1	DCLK	2	GND	3 to 10	DATA 7 to DATA 0	11	DVALID	12	PSYNC	13	Shield	14	DCLK	15	GND	16 to 23	<u>DATA 7</u> to <u>DATA 0</u>	24	<u>DVALID</u>	25	<u>PSYNC</u>
1	DCLK																						
2	GND																						
3 to 10	DATA 7 to DATA 0																						
11	DVALID																						
12	PSYNC																						
13	Shield																						
14	DCLK																						
15	GND																						
16 to 23	<u>DATA 7</u> to <u>DATA 0</u>																						
24	<u>DVALID</u>																						
25	<u>PSYNC</u>																						
Input																							
Input level, typical	> +100 mV, < -100 mV, (RI+)-(RI-) with 100 $\Omega$ termination																						
Input resistance, typical	100 $\Omega$ (between differential inputs)																						
Clock pulse width, typical	$T/2 \pm T/10$ , $T=1/f$ (f=byte clock frequency) (see Figure 1-1 on page 1-13)																						
Data hold time, typical	$T/2 \pm T/10$ , $T=1/f$ (f=byte clock frequency, Data are latched on DCLK rising edge) (see Figure 1-1 on page 1-13)																						

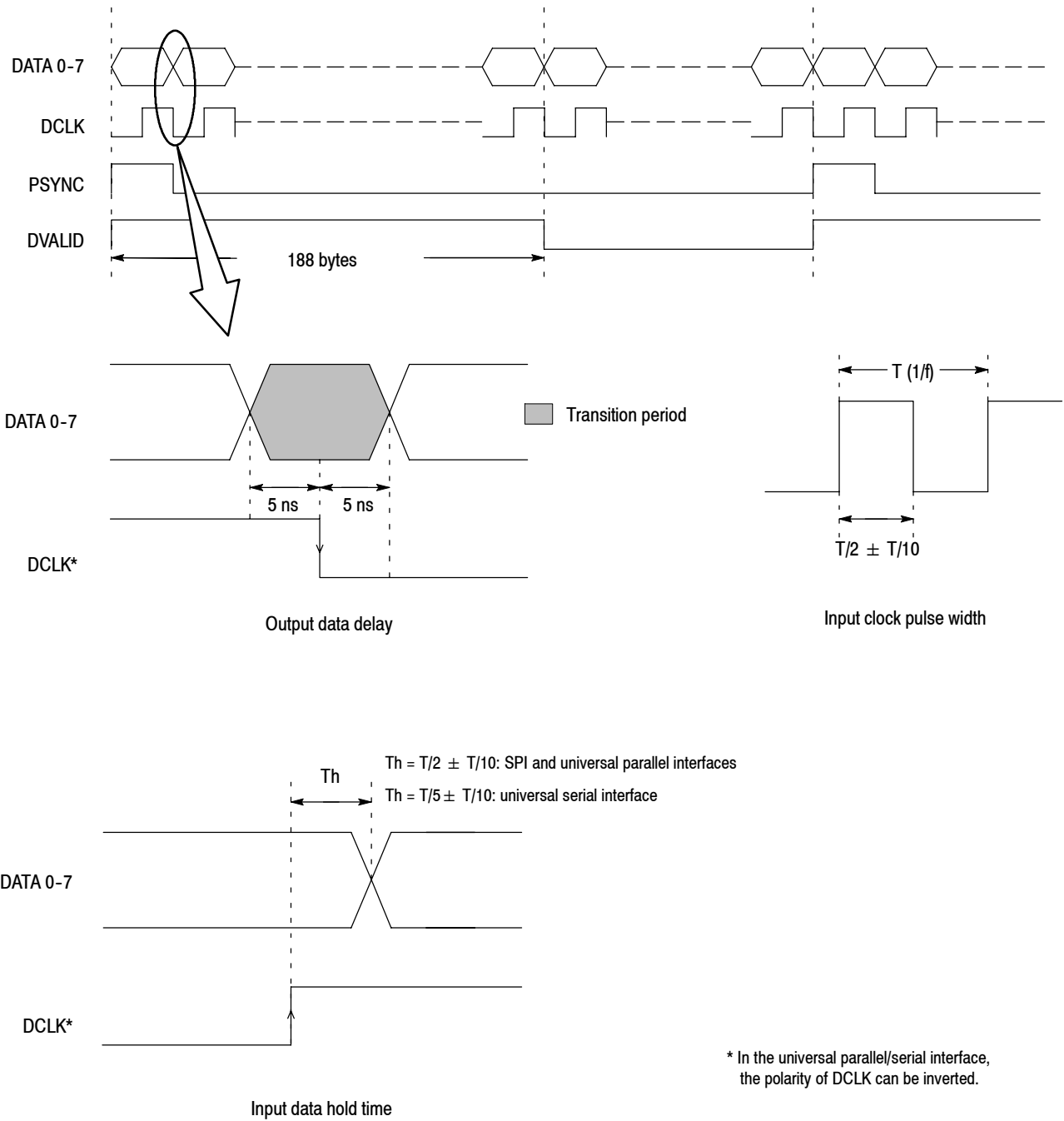

Figure 1-1: Timing diagram of the SPI and universal parallel/serial interfaces

## Mechanical (Physical) Characteristics

**Table 1-7: Mechanical characteristics**

Characteristics	Description
Net weight	
Standard	Approximately 6 kg (13.2 lb)
Dimensions	
Height	132 mm (5.1 in), without feet
Width	214 mm (8.4 in)
Length	435 mm (17.1 in)

## Environmental Characteristics

**Table 1-8: Environmental characteristics**

Characteristics	Description
Temperature	
Operating	+5 °C to +40 °C
Non-operating	-20 °C to +60 °C
Relative humidity	
Operating	20% to 80% (No condensation) Maximum wet-bulb temperature 29 °C
Non-operating	5% to 90% (No condensation) Maximum wet-bulb temperature 29 °C
Altitude	
Operating	Up to 3 km (approximately 10,000 feet) Maximum operating temperature decreases 1 °C each 300 m above 1.5 km
Non-operating	Up to 15 km (approximately 50,000 feet)
Dynamics	
Vibration	
Operating	2.65 m/s <sup>2</sup> rms (0.27 Grms), 5 Hz to 500 Hz, 10 min, three axes
Non-operating	22.3 m/s <sup>2</sup> rms (2.28 Grms), 5 Hz to 500 Hz, 10 min, three axes
Shock	
Non-operating	294 m/s <sup>2</sup> (30 G), half-sine, 11 ms duration
Installation requirements	
Power dissipation	100 W maximum. Maximum line current is 1.3 A <sub>rms</sub> at 50 Hz

**Table 1-8: Environmental characteristics (Cont.)**

Characteristics	Description
Surge current	$\leq 12$ A peak for less than 5 line cycles at 25 °C after product has been off for at least 30 seconds
Cooling clearance	
Top clearance	5 cm (2 in)
Side clearance	5 cm (2 in)
Rear clearance	5 cm (2 in), from the fan guard

## Certifications and Compliances

**Table 1-9: Certifications and compliances**

Category	Standards or description																		
EC Declaration of Conformity	<p>Meets the intent of Directive 89/336/EEC for Electromagnetic Compatibility. Compliance was demonstrated to the following specifications as listed in the Official Journal of the European Communities:</p> <p>EMC Directive 89/336/EEC:</p> <table> <tbody> <tr> <td>EN 55011</td> <td>EMC requirement for Class A electrical equipment for measurement, control and laboratory use</td> </tr> <tr> <td>EN 61000-3-2</td> <td>AC Power Line Harmonic Emissions</td> </tr> <tr> <td>IEC 61000-4-2</td> <td>Electrostatic Discharge Immunity (Performance Criterion B)</td> </tr> <tr> <td>IEC 61000-4-3</td> <td>RF Electromagnetic Field Immunity (Performance Criterion A)</td> </tr> <tr> <td>IEC 61000-4-4</td> <td>Electrical Fast Transient / Burst Immunity (Performance Criterion B)</td> </tr> <tr> <td>IEC 61000-4-5</td> <td>Power Line Surge Immunity (Performance Criterion B)</td> </tr> <tr> <td>IEC 61000-4-6</td> <td>Conducted RF Immunity (Performance Criterion A)</td> </tr> <tr> <td>IEC 61000-4-11</td> <td>Voltage Dips and Interruptions Immunity (Performance Criterion B)</td> </tr> </tbody> </table> <p>Low Voltage Directive 73/23/EEC: Amended by 93/68/EEC:</p> <table> <tbody> <tr> <td>EN 61010-1: 2001</td> <td>Safety Requirements for Electrical Equipment for Measurement, Control, and Laboratory Use</td> </tr> </tbody> </table>	EN 55011	EMC requirement for Class A electrical equipment for measurement, control and laboratory use	EN 61000-3-2	AC Power Line Harmonic Emissions	IEC 61000-4-2	Electrostatic Discharge Immunity (Performance Criterion B)	IEC 61000-4-3	RF Electromagnetic Field Immunity (Performance Criterion A)	IEC 61000-4-4	Electrical Fast Transient / Burst Immunity (Performance Criterion B)	IEC 61000-4-5	Power Line Surge Immunity (Performance Criterion B)	IEC 61000-4-6	Conducted RF Immunity (Performance Criterion A)	IEC 61000-4-11	Voltage Dips and Interruptions Immunity (Performance Criterion B)	EN 61010-1: 2001	Safety Requirements for Electrical Equipment for Measurement, Control, and Laboratory Use
EN 55011	EMC requirement for Class A electrical equipment for measurement, control and laboratory use																		
EN 61000-3-2	AC Power Line Harmonic Emissions																		
IEC 61000-4-2	Electrostatic Discharge Immunity (Performance Criterion B)																		
IEC 61000-4-3	RF Electromagnetic Field Immunity (Performance Criterion A)																		
IEC 61000-4-4	Electrical Fast Transient / Burst Immunity (Performance Criterion B)																		
IEC 61000-4-5	Power Line Surge Immunity (Performance Criterion B)																		
IEC 61000-4-6	Conducted RF Immunity (Performance Criterion A)																		
IEC 61000-4-11	Voltage Dips and Interruptions Immunity (Performance Criterion B)																		
EN 61010-1: 2001	Safety Requirements for Electrical Equipment for Measurement, Control, and Laboratory Use																		
Australia/New Zealand Declaration of Conformity - EMC	<p>Complies with EMC provision of Radio Communications Act per the following standard(s):</p> <table> <tbody> <tr> <td>AS/NZS 2064.1/2</td> <td>Industrial, Scientific, and Medical Equipment: 1992</td> </tr> </tbody> </table>	AS/NZS 2064.1/2	Industrial, Scientific, and Medical Equipment: 1992																
AS/NZS 2064.1/2	Industrial, Scientific, and Medical Equipment: 1992																		

**Table 1-9: Certifications and compliances (Cont.)**

Category	Standards or description
Safety	<p>Complies with the following safety standards/regulations:</p> <p>UL 61010-1                      Standard for Electrical Measuring and Test Equipment.</p> <p>CAN/CSA C22.2 No.61010-1-04   Safety Requirements for Electrical Equipment for Measurement, Control, and Laboratory Use.</p> <p>EN 61010-1:2001                      Safety Requirements for Electrical Equipment for Measurement, Control, and Laboratory Use.</p>
Installation (Overvoltage) Category	<p>Terminals on this product may have different installation (overvoltage) category designations. The installation categories are:</p> <p>CAT III      Distribution-level mains (usually permanently connected). Equipment at this level is typically in a fixed industrial location.</p> <p>CAT II      Local-level mains (wall sockets). Equipment at this level includes appliances, portable tools, and similar products. Equipment is usually cord-connected.</p> <p>CAT I      Secondary (signal level) or battery operated circuits of electronic equipment.</p>
Overvoltage Category	Overvoltage Category II (as defined in IEC 61010-1)
Pollution Degree	<p>A measure of the contaminates that could occur in the environment around and within a product. Typically the internal environment inside a product is considered to be the same as the external. Products should be used only in the environment for which they are rated.</p> <p>Pollution Degree 1      No pollution or only dry, nonconductive pollution occurs. Products in this category are generally encapsulated, hermetically sealed, or located in clean rooms.</p> <p>Pollution Degree 2      Normally only dry, nonconductive pollution occurs. Occasionally a temporary conductivity that is caused by condensation must be expected. This location is a typical office/home environment. Temporary condensation occurs only when the product is out of service.</p> <p>Pollution Degree 3      Conductive pollution, or dry, nonconductive pollution that becomes conductive due to condensation. These are sheltered locations where neither temperature nor humidity is controlled. The area is protected from direct sunshine, rain, or direct wind.</p>
Pollution Degree	Pollution Degree 2 (as defined in IEC 61010-1). Note: Rated for indoor use only.
IEC Characteristics	<p>Equipment type:</p> <p>Test and Measuring</p> <p>Safety Class 1 - grounded product</p>



# Theory of Operation





# Theory of Operation

This section describes the basic operation of the major circuit blocks or modules in the MTX100B. The *Diagrams* section, beginning on page 6-1, includes a block diagram and an interconnect diagram.

## A12 Main Board

The A12 Main board consists of the following blocks:

**PCI Interface** The PCI interface consists of a PCI target and a PCI master. The PCI target has three base address register areas. The PCI master has two DMA controllers used to transfer data from the A12 Main board to the system memory or from the system memory to the A12 Main board.

**Mega FIFO** The Mega FIFO has 32 MB for playing and 32 MB for recording a stream data. It consists of two 256 megabit synchronous DRAM and FPGA. This FIFO is used to compensate for non-realtime operation of Windows XP.

**TS Controller** The TS controller consists of the following blocks:

**TS Packet Type Controller.** This controller sets a packet size of 188, 204, 208, and Non TS (free length) as a TS packet type. For a Non TS format, the controller also sets a packet length (16-255) and data length (16-255). The data length shows an effective data length in one TS packet.

**Data Valid Controller.** This block generates a data valid signal that synchronizes with the first byte of a TS packet when stream output is started.

**Psync Controller.** Psync is a signal to identify the sync byte in a transport stream. When the controller is not in the Psync Regeneration mode, Psync is recognized as the first byte of a transport stream. In this case, Psync is output in the constant interval even when the sync byte is rewritten in the value except for 47h. For the Super Frame mode, Psync is output only once in 384 packets.

**Psync Regenerator.** This block becomes active when the Psync Regeneration mode is set. The block detects the sync byte (47h) in a data stream and regenerates a Psync signal. The psync generator supports 188, 204, 208 TS packets only.

**PCR/DTS Updater.** This block consists of a PCR counter and update logic. The PCR counter is a complex counter, which consists of a 9-bit counter (range 0-299) and 33-bit counter. The counter counts the 27 MHz standard frequency. The update logic replaces the PCR and PTS/DTS values in a transport stream with the sum of the original value and the PCR counter value.

**Receive Rate Counter.** This 24-bit counter is used for receive-rate calculation on recording process. When using a data valid signal (DVALID), the counter counts byte data rate. When not using DVALID, the counter counts receive clock.

**Transmit Byte Counter.** This 32-bit counter counts transmitted bytes. This counter can be read by the control software.

**Interrupt Controller** The interrupt controller sends the following interruption signals to the CPU: Play FIFO empty, Record FIFO full, external trigger, 10 Hz, Playout DMA transfer finished, and Record DMA transfer finished. These interruptions can be disabled by the MTX100B application software. At power on, all interruptions are disabled.

**TS Clock Generator** The TS clock generator consists of a VCO (Voltage Control Oscillator), phase detector, frequency divider. The VCO is used for generating a TS clock, and it covers frequencies of 400 MHz to 800 MHz. The frequency divider divides the clock by 65536 to 1.

**Reference Clocks** The reference clocks consist of 27 MHz TCXO and half-divided output of 54 MHz clock generator. These clocks are used to compare the frequency of the TS Clock Generator.

## A20 PCI Backplane Board

The A20 PCI Backplane board consists of the following connectors and circuitries:

**PCI and ISA Connectors** The J100, J110, and J120 connectors are PCI slots for 5 V. The J130 connector is a PCI slot for 3.3 V and is reserved in the future. The J100 connector is the system slot and is used to install the CPU board (single board computer: SBC). The J110 and J120 connectors are used to install the A12 Main board and a optional interface board.

<b>ATX Power Control Circuit</b>	The PWR_Button line (Pins 9 and 10 of J310) of the SBC is connected to the power switch on the Keypad board through the Front-Panel Processor board. When the power switch is pressed, the SBC causes the PSON# signal to go Low. When the PSON# signal becomes Low, Q10 turns on and +12 V main power is also on. When the power switch is pressed again, its status is sent to BIOS and the PSON# signal turns High. This circuit includes a +12 V to +5 V DC-DC converter, a +12 V to +3.3 V converter, and a +12 V to -12 V converter.
<b>Interconnect Circuit</b>	There are four connectors in the interconnect circuit: J230, J240, J290, and J310. J230 is used to connect the board to the LCD interface on the CPU board. J290 is used to connect the board to COM2 on the CPU board. J310 is used to connect the board to the hard disk drive LED and reset/power button on the CPU board. J240 is used to connect the board to the Front-Panel Processor board. This circuit also has a RS-232C level converter.
<b>Fan Speed Control Circuit</b>	U700 (PIC Micro) controls the internal fan revolution. It gets the temperature data from the sensors (U720 and U730) through 12C BUS and controls the supply voltage to the fan (7 V to 11.5 V).
<b>IEEE1394b Interface</b>	The IEEE1394 interface consists of the 1394b link-layer device (U110), cable transceiver/arbitrator (U120), oscillator (Y100), serial EEPROM (U140), regulators (U130 and U230), and IEEE1394b connector (J140).

## Front-Panel Processor Board

The Front-Panel Processor board consists of the following circuitries and connectors:

<b>Front-panel Keypad Interface and LED Control</b>	The state of the front-panel keys are read by the one chip processor on the board and any setting changes are reported to the SBC through the COM2. The processor also controls the LED on/off state of the front-panel LEDs.
<b>LVDS Data for LCD</b>	The LVDS data from the SBC is routed through the board to the LCD.
<b>Backlight Power Control</b>	When the Window OS puts the instrument into power saver mode, the LVDS data from the SBC stops and the LCD backlight needs to be turned off or a rainbow display will occur. When the LVDS data stops, the common mode voltage of the data lines changes from the normal + 1.25 V to 0 V. The comparator U10 senses this voltage change and turns off the power MOSFET switch Q10 and the power to the backlight inverter board.

**LCD Brightness Control** The potentiometer R301 could be used to dim the LCD backlight brightness. But R302 is not installed, so the adjustment has no effect and the backlight is at maximum brightness.

**USB Ports** There are two USB connectors on the board that are connected through a cable to the USB 2.0 interface connector on the CPU board.

## Keypad Board

The Keypad board contains the switch patterns for the elastomer keys and the front-panel LEDs. The board is connected to the Front-Panel Processor board by the board-to-board connectors J10 and J11.

## A40 AC Distributor Board

The A40 AC Distributor board supplies standby power (5VSB) to the SBC and the ATX power control circuit on the A20 Backplane board.

## A100 ASI Interface Module (Option 01)

The A100 ASI Interface module consists of the following blocks:

**Local Bus Interface** The local bus interface communicates with the A12 Main board. There are two sets of 16-bit signal lines for Rx and Tx: 8-bit data lines for single-end connection, 4-bit control lines for single-end connection, and 4-bit control lines for differential connection. These lines are connected to the A12 Main board individually.

**FPGA** The FPGA consists of an FIFO and a PCI interface. The FIFO is used to output a stream data in packet mode. In this mode, a stream data from the A12 Main board is stored in it, and then the data is output synchronously with the PSYNC signal. In the burst mode, the FIFO is used only to synchronize with the clock signal. There is a 32-bit resistor in the PCI interface and it controls the board operation.

**Packet Controller** Two operational modes are available to output data from the ASI interface: Packet mode and Byte mode.

**Difference between Packet and Byte Modes.** Data rate of the ASI interface is up to 216 Mbps, and the data with rates lower than 216 Mbps are transmitted intermittently. The Data Valid signal, which indicates the location in which the data exists, is also sent together with the data, it is possible to reconfigure the received data as a serial data string from the intermittently transmitted data.

When the data rate from the MTX100B storage (hard disk or RAM) is lower than 216Mbps, it is possible to select whether to sparsely output all the data or to output the data on a packet-by-packet basis as the ASI output. The first mode in which the data is sparsely output is called Byte mode, and the second mode in which the data is output on a packet-by-packet basis is called Packet mode. In Byte mode, the data sent from the A12 board are output as they are. In Packet mode, data processing is required.

**Packet Mode Operation.** The FIFO shift register is used to output the data on a packet-by-packet basis. This FIFO has 9 bits of width, and its depth is 512 stages. The content of 9-bit width is 8 bits for data, and 1 bit for Sync Bit. The Sync bit indicates the location of sync pattern (47h) in the data.

The data sent from the A12 board is fed to the FIFO. The FIFO output port searches for a Sync Bit. When a Sync Bit is detected, data output from the FIFO is stopped, and the data that follows the Sync Bit is stored in the FIFO.

The FIFO input port also searches for a Sync Bit. When the port detects a Sync Bit in the next packet, it sends the detection to the read-out controller at the FIFO output port. When the FIFO output port receives the Sync Bit detection signal from the input port, the output port reads out the signals until the next packet Sync Bit is detected. The data rate of FIFO input port is equal to the data transfer rate of the MTX100B, and that of output port is 216 Mbps (with the clock of 27 MHz), which is used for the ASI output.

**HOTLink transmitter and Cable Drivers** The HOTLink transmitter converts parallel signals from the FIFO to a serial signal. The converted signal is output to the BNC connectors through the cable drivers.

**Cable Equalizer and HOTLink Receiver** The signal applied to the BNC connector is equalized by the cable equalizer, and is converted to parallel signals by the HOTLink receiver. In addition, the equalized signal is applied to the cable driver, and is output to the ASI through output.

**2.5 V Regulator** The regulator supplies power for internal circuitry in the FPGA.

## A110 Universal Parallel/Serial Interface Module (Option 02)

The A110 Universal Parallel/Serial Interface module consists of the following blocks:

### Local Bus Interface

The local bus interface communicates with the A12 Main board. There are two sets of 16-bit signal lines for Rx and Tx: 8-bit data lines for single-end connection, 4-bit control lines for single-end connection, and 4-bit control lines for differential connection. These lines are connected to the A12 Main board individually.

### FPGA

The FPGA consists of an 8-bit-to-1-bit shift register for parallel to serial conversion, a 1-bit-to-8-bit shift register for serial to parallel conversion, and a PCI interface. The shift registers are not used in the parallel data input/output mode. There is a 32-bit resistor in the PCI interface. It controls the board operation.

### Pin Drivers

The pin drivers convert output signals from the FPGA into the signals with the selected level. Two drivers per 1 bit are always working: two drivers are used for differential mode and one driver is used for single-end mode.

### Receivers

The receivers use two comparators per 1 bit. One is used to receive a single-end signal and the other is used to receive a differential signal. One of the comparators is always disabled in operation and is in hold mode.

### D/A Converter

The D/A converter is used to set the amplitude and offset of the output signal. It also sets the threshold voltage of the comparator for single-end receiving.

### 2.5 V Regulator

The regulator supplies power for internal circuitry in the FPGA.

## A140 IEEE 1394/ASI Interface Module (Option 05)

### Packet Controller

Two operational modes are available to output data from the ASI interface: Packet mode and Byte mode.

**Difference between Packet and Byte Modes.** Data rate of the ASI interface is up to 216 Mbps, and data with rates lower than 216 Mbps is transmitted intermittently. The Data Valid signal, which indicates the location in which the data exists, is also sent together with the data; it is possible to reconfigure the received data as a serial data string from the intermittently transmitted data.

When the data rate from the MTX100B storage (hard disk or RAM) is lower than 216 Mbps, it is possible to select whether to sparsely output all the data or to output the data on a packet-by-packet basis as the ASI output. The first mode in which the data is sparsely output is called Byte mode, and the second mode in which the data is output on a packet-by-packet basis is called Packet mode.

In Byte mode, the data sent from A12 board is output as they are. In Packet mode, data processing is required. The data is organized into a packet within the Link chip and then output. The Packet controller is not used in this process. The Packet controller must be set to Byte mode.

In through mode where the data is sent from the ASI input to the ASI output, the data does not pass through the packet controller circuit and are output with the same timing as the ASI input.

**Packet Mode Operation.** The FIFO shift register is used to output the data on a packet-by-packet basis. This FIFO has 9 bits of width, and its depth is 512 stages. The content of 9-bit width is 8 bit for data, and 1 bit for Sync Bit. The Sync Bit indicates the location of sync pattern (47h) in the data.

The data sent from the A12 board is fed to the FIFO. The FIFO output port searches for a Sync Bit. When a Sync Bit is detected, data output from the FIFO is stopped, and the data that follows the Sync Bit is stored to the FIFO.

The FIFO input port also searches for a Sync Bit. When the port detects a Sync Bit in the next packet, it sends the detection to the read-out controller at the FIFO output port. When the FIFO output port receives the Sync Bit detection signal from the input port, the output port reads out the signals until the next packet Sync Bit is detected. The data rate of FIFO input port is equal to the data transfer rate of the MTX100B, and that of the output port is 216 Mbps (with a clock of 27 MHz), which is used for the ASI output.

### **Partial TS Controller**

The partial transport stream is a bit stream generated by removing the transport packets unrelated to selected audio/video program(s) from MPEG-2 transport packets. In transmitting/receiving multiple numbers of audio/video programs with a lower data rate through a high-speed data line, the packets in a single audio/video program are transmitted as intermittent packets compressed along the time axis. In this case, the period of time between the packets has some meaning. When recording data in the MTX100B, all the packets are recorded as a serial data. When reproducing such data, the time information between packets are lost and the data becomes a serial data.

To resolve the problem mentioned above, the period of time between the received packets are measured, and the timing information is added before the Sync byte of each packet as 4 bytes data. In reproducing the data, the timing information located before the next packet is derived after the packet is output.

The next packet is output after waiting for the period of time as written in this four bytes of data.

**Partial TS Controller 1.** The Partial TS Controller 1 picks up 4 bytes of data located before sync byte from the data stream sent from A12 board, and counts down the value written in this 4 bytes data with the 27 MHz clock. When the count becomes zero, the controller starts the processing on the next packet. While waiting for the next sync byte, the controller outputs The Busy signal to stop the operation of A12 board. The packet size that can be handled by the Partial TS Controller 1 is fixed to 192 bytes/packet (188 + 4). When sending packets of other sizes, turn the Partial TS processing off. This board uses only 24 bits out of 32 bits (4 bytes) of Time Stamp information. The upper 8 bits are ignored.

**Partial TS Controller 2.** This controller performs the opposite operation to that of the Partial TS Controller 1. It counts the period of time between the packets being received with the 27 MHz clock, and adds the result of counting to the top of the next packet as the time information of 4 bytes. Because a 24-bit counter is used, the first byte of 4 bytes of data becomes zero. While 4 bytes of information is output, the controller stops input of packets. The controller has the FIFO shift register of 9 bit x 256 to retain the data during the suspension period.

### Sync Detector

Although the packets received from IEEE1394 or from ASI contain Sync Pattern (47h), the 47h may be contained within data or the 47h may be missing because of an error. The sync detector reconfigures information indicating the sync location and delivers the information to the next block together with the data. In the output circuit of IEEE1394, the packets are generated based upon this sync location information. In the Partial TS Controller, the measurements of time interval between packets are performed based upon this information.

**Sync Detector 1.** The Sync Detector 1 produces sync location information to be delivered to IEEE1394 output circuit. This information is also used to send the received packet size to the application. This circuit is compatible with the packet sizes of 188, 204, and 208. After repeated confirmation that “47h” is located at the same location (188, 204, or 208) for five (5) times, the circuit starts to output the sync location information. When the circuit failed to find the location of “47h” for three consecutive times, it stops outputting the sync location information. The circuit sends information of 1, 2, or 3 to the application when the packet size is 188, 204, or 208, respectively. Otherwise, it sends information of zero (0). This information is needed to use the through mode for the IEEE1394 output.



**Sync Detector 2.** This circuit produces the sync location information to be delivered to the Partial TS Control 2 circuit. The circuit is compatible only with the packet size of 188 bytes/packet. Should a packet having a size other than 188 bytes/packet be input even if Partial TS processing is specified, the circuit stops the output to the A12 board.

## A170 SMPTE310M/ASI/PSI Interface Module (Option 07)

**SMPTE310M** The SMPTE310M format supports data with a bit rate of 8-VSB (19.39 Mbps). Because the SMPTE310M uses Biphase-mark coding, a clock with twice the data bit rate (40 MHz) is required for decoding and encoding processes. The receiver passes the received data signal through a delay line to generate a clock signal with twice the data bit rate from the received data signal. The transmitter receives the clock signal with twice the data bit rate from A12 board for data encoding. Because this optional board is unable to recognize the difference of data bit rates, the current data bit rate must be specified from the application.

**Packet Controller** Two operational modes are available to output data from the ASI interface: Packet mode and Byte mode.

**Difference between Packet and Byte Modes.** Data rate of the ASI interface is up to 216 Mbps, and the data with rates lower than 216 Mbps are transmitted intermittently. The Data Valid signal, which indicates the location in which the data exists, is also sent together with the data. It is possible to reconfigure the received data as a serial data string from the intermittently transmitted data.

When the data rate from the MTX100B storage (hard disk or RAM) is lower than 216Mbps, it is possible to select whether to sparsely output all the data or to output the data on a packet-by-packet basis as the ASI output. The first mode in which the data is sparsely output is called Byte mode, and the second mode in which the data is output on a packet-by-packet basis is called Packet mode. In Byte mode, the data sent from the A12 board are output as they are. In Packet mode, data processing is required.

**Packet Mode Operation.** The FIFO shift register is used to output the data on a packet-by-packet basis. This FIFO has 9 bits of width, and its depth is 512 stages. The content of 9-bit width is 8 bits for data, and 1 bit for Sync Bit. The Sync bit indicates the location of sync pattern (47h) in the data.

The data sent from the A12 board is fed to the FIFO. The FIFO output port searches for a Sync Bit. When a Sync Bit is detected, data output from the FIFO is stopped, and the data that follows the Sync Bit is stored in the FIFO.

The FIFO input port also searches for a Sync Bit. When the port detects a Sync Bit in the next packet, it sends the detection to the read-out controller at the FIFO output port. When the FIFO output port receives the Sync Bit detection signal from the input port, the output port reads out the signals until the next packet Sync Bit is detected. The data rate of FIFO input port is equal to the data transfer rate of the MTX100B, and that of the output port is 216 Mbps (with a clock of 27 MHz), which is used for the ASI output.

### **A12 Board I/O**

When receiving SMPTE310M or ASI data, both the enabling and 27 MHz clock signal are delivered to the A10 board. The option 06 can convert the data from SMPTE310M into ASI, however it is unable to convert the ASI data into the SMPTE310M format.

To transmit data in the SMPTE310M format, an enabling signal and clock signal (approximately 77.56 MHz) for encoding the Biphase-mark are required. When transmitting data in the ASI format, the enabling signal, the signal indicating the location of sync bit, and the transport stream clock are generated from the A10 board.



# Performance Verification



# Performance Verification

This section provides procedures to verify the performance and functionality of the MTX100B.

## Equipment Required

Table 3-1 lists the test equipment required to perform all of the performance verification procedures. The table identifies examples of recommended equipment and lists the required precision where applicable. If you substitute other test equipment for the examples listed, the equipment must meet or exceed the listed tolerances.

**Table 3-1: Equipment required for performance verification**

Item	Qty.	Minimum requirements	Recommended equipment
Frequency counter	1 ea.	Frequency range: 27 MHz Precision: 8 digits or higher	Agilent Technologies 53181A
MPEG analyzer	1 ea.		Tektronix MTS430 or MTS400
Function generator	1 ea.	Frequency: 40 M clock pattern Amplitude: 3 V Outputs: 2 channel	Tektronix AFG3102
Oscilloscope	1 ea.	Bandwidth: 1 GHz or higher	Tektronix TDS5104B
D-VHS digital recorder	1 ea.		JVC HM-DH5U
MPEG recorder and player	1 ea.		Tektronix MTX100A(B) Option 02
Video monitor	1 ea.		Sony LMD-1420
Probe	1 ea.		Tektronix P5050
75 $\Omega$ signal adapter	1 ea.	Bandwidth: 1 GHz Amplitude precision: -3 dB	Tektronix AMT75
50 $\Omega$ BNC cable	2 ea.	Length: 42 inches	Tektronix part number 012-0057-01
75 $\Omega$ BNC cable	2 ea.	Length: 42 inches	Tektronix part number 012-0074-00
Parallel interface cable	1 ea.	25-pin, D-type	Tektronix part number 012-A220-00 (supplied with the MTX100B)
IEEE1394b cable	1 ea.	9 pin-9 pin	
IEEE1394 cable	1 ea.	4 pin-4 pin	
RCA(Ma)-to-BNC(Fe) adapter	1 ea.		Zifor Enterprise BJ-7071
IEEE1394b hard disk drive	1 ea.		Novac NV-HD352WB and hard disk drive (Tektronix part number 119-7146-00)

## MTX100B Test Record

Photocopy this page and use it to record the performance test result.

**Table 3-2: MTX100B test record**

<b>Serial Number:</b>	<b>Cal Date:</b>	<b>Temperature:</b>	<b>Humidity:</b>
<b>Performance Test</b>	<b>Minimum</b>	<b>Measured</b>	<b>Maximum</b>
Internal Clock Frequency	26.999973 MHZ	MHz	27.000027 MHz

## Procedures

The following conventions are used in the performance verification procedures:

- Each test lists the characteristic that is being tested and the equipment required to perform the test.
- Each test contains complete setup instructions, which allows you to perform each test individually or in order.
- The equipment connection illustrations are specific to the recommended equipment (equipment nomenclature is labeled). If you are using substitute equipment, the location of your signal connections may vary from those in the illustrations.

---

**NOTE.** *Before you begin the performance verification procedures, be sure that the MTX100B is operating in an environment that is within the operating limits described in Table 1-8 on page 1-14.*

*In addition, the MTX100B and the test equipment must be warmed up for at least 20 minutes to ensure accurate test results.*

---

**Internal Clock Output Level and Frequency Accuracy**

This test verifies the internal clock output level and frequency accuracy.

<b>Equipment required</b>	Oscilloscope
	Frequency counter
	50 Ω BNC cable

1. Use the 50 Ω BNC cable to connect the Trig In/Out connector on the MTX100B to the oscilloscope CH1 input. See Figure 3-1.

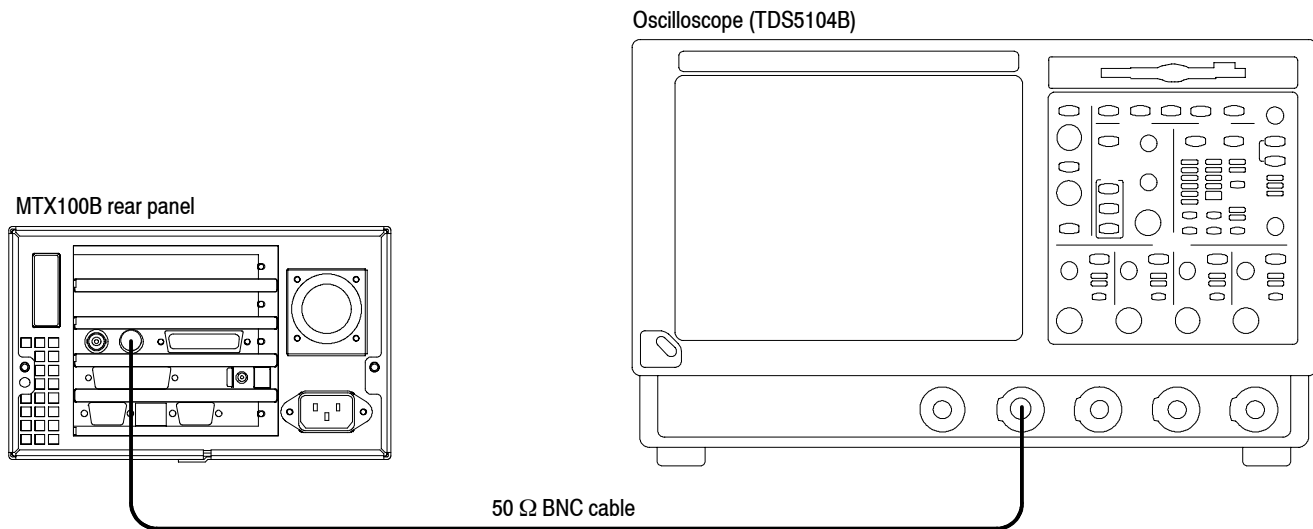

**Figure 3-1: Equipment connection for verifying the internal clock output level**

2. Set the oscilloscope as indicated below:

- Vertical scale . . . . . 1 V/div (CH1)
- Input impedance . . . . . 50 Ω
- Horizontal scale . . . . . 10 ns/div
- Trigger position . . . . . 50%
- Acquire mode . . . . . Average 16
- Trigger mode . . . . . Auto
- Trigger level . . . . . 1.20 V
- Trigger source . . . . . CH1
- Trigger slope . . . . . Rising Edge
- Input coupling . . . . . DC
- Measure . . . . . High Level, Low level

3. Select **Play > Others** on the MTX100B to open the **Others** dialog box.



4. In the dialog box, select the **Ext Trigger BNC** button to open the Ext Trigger BNC dialog box.
5. In the dialog box, set **BNC IN/OUT** to **Output** and **BNC OUT Selection** to **27MHz**.
6. Verify that the measured values are as follows:
  - High Level: > 2.2 V
  - Low Level: < 0.8 V
7. Disconnect the 50  $\Omega$  BNC cable from the oscilloscope CH1 input, and then connect the BNC cable to the CH1 connector on the frequency counter. See Figure 3-2.

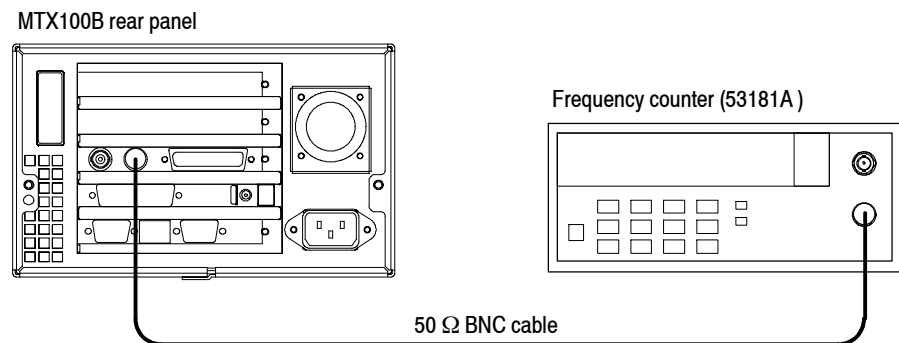

**Figure 3-2: Equipment connection for verifying the internal clock frequency**

8. Set the frequency counter settings as indicated below:
  - MEASURE . . . . . Frequency1
  - Gate Time: 0.20 s
  - CHANNEL1 . . . . . Coupling: DC
  - Impedance: 50
  - Trigger: AUTO TRIG ON
9. Verify that the frequency counter reading falls within the range of 26.999973 MHz to 27.000027 MHz (< 1.0 ppm).
10. In the Ext Trigger BNC dialog box, change **BNC IN/OUT** to **Input**.
11. Disconnect the BNC cable from the MTX100B and frequency counter.

**SPI Interface** This test verifies that transport stream data is correctly played from and recorded through the SPI In/Out connector on the MTX100B.

<b>Equipment required</b>	MPEG analyzer Parallel interface cable test40.TRP file
---------------------------	--

**Checking the Play Operation.**

1. Use the parallel interface cable to connect the SPI In/Out connector on the MTX100B to the DVB SPI In connector on the MPEG analyzer. See Figure 3-3.

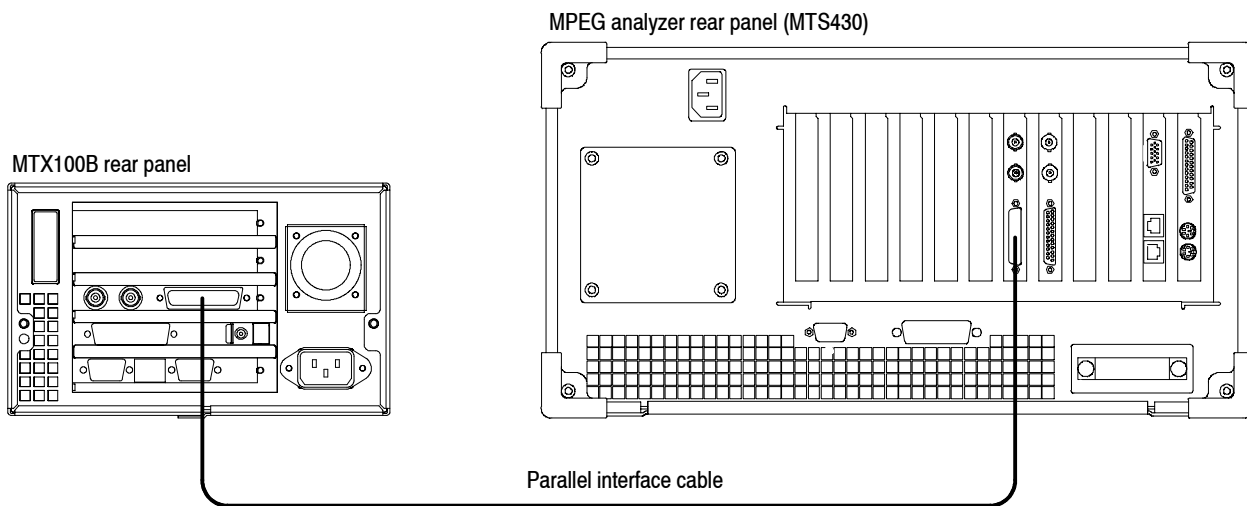

**Figure 3-3: Equipment connection for verifying the SPI interface**

2. Start the **MPEG Player** application on the MPEG analyzer.
3. Set the application to the Record mode.

4. Set the MPEG analyzer settings as indicated below:

**Record**

Source . . . . . SPI  
Target . . . . . RAM, Size: 100 MB

**File**

Save Mode . . . . . Overwrite  
Save . . . . . E:\MTXRTX\_Test streams\Record\_Files\  
SPI214Mbps

5. Open the **test40.TRP** file on the MTX100B.
  - a. Select **File > Open** in the Play screen to open the **Select File** dialog box.
  - b. In the dialog box, select the **test40.TRP** file.
6. In the **Play** menu, make the following settings:

Clock . . . . . Data Rate: 214 Mbps  
Update . . . . . Off  
Source . . . . . RAM
7. Press the **Play/Pause** button on the MTX100B to start playing the test40.TRP file.
8. Verify that the hierarchic view is displayed on the MPEG analyzer screen. In addition, verify that the bit rate is **214 Mbps** and the packet size is **188** bytes.
9. Click the **Record** button on the MPEG Player application to record the file.
10. After recording is completed, press the **Stop** button on the MTX100B.

**Checking the Record Operation.**

11. Change the interface cable connection from the DVB/SPI In connector to the DVB/SPI Out connector on the MPEG analyzer.
12. Press the **Record** button on the MTX100B to display the Record screen.

13. On the MTX100B, make the following settings:

**Record menu**

Source . . . . . SPI  
Target . . . . . RAM  
Record Size . . . . . 100 MB  
Save Mode . . . . . Over Write

**File menu**

Save Mode . . . . . Over Write  
Save Mode . . . . . D:\Record\_Files\SPI214Mbps

14. Change the MPEG analyzer to the Play mode.
15. Select **File > Open** on the MPEG analyzer to display the **Open** dialog box.
16. In the dialog box, navigate to the **E:\MTXRTX\_Test streams\  
Record\_Files**, and then select the **SPI214Mbps.trp** file.
17. Set the MPEG analyzer settings as indicated below:

Data Rate . . . . . 214 Mbps  
Update . . . . . Off  
Source . . . . . RAM

18. Click the **Play/Pause** button on the MPEG Analyzer to start playing the **SPI214Mbps.trp** file.
19. Verify that the hierarchic view is displayed on the MTX100B screen. In addition, verify that the bit rate display is **214 Mbps** and the packet size display is **188** bytes.
20. Press the **Record** button on the MTX100B to record the file.
21. After recording is completed, click the **Stop** button on the MPEG analyzer.
22. Exit the MPEG Player application on the MPEG analyzer.

**Checking the Recorded File.**

23. Change the interface cable connection from the DVB/SPI Out connector to the DVB/SPI In connector on the MPEG analyzer.
24. Start the **TS Compliance Analyzer** on the MPEG analyzer.
25. In the **Open Transport Stream** dialog box, select **Real-time Analysis**, and then make the following settings

Interfaces . . . . . DVB Parallel  
Interface Settings . . . . Time Stamping

26. Click the **OK** button.

27. Press the **Play/Pause** button on the MTX100B to display the Play screen.
28. Select **File > Open** to open the **Select File** dialog box.
29. In the dialog box, navigate to the **D:\ Record\_Files** directory, and then select the **SPI214Mbps.trp** file.
30. Select **Play > Update > On**.
31. Press the **Play/Pause** button on the MTX100B to start playing the SPI214Mbps.trp file.
32. Verify that the hierarchic view is displayed on the MPEG analyzer screen and that no error messages appear. In addition, verify that the bit rate is **40 Mbps** and that the transport stream packet size is **188** bytes.

---

**NOTE.** Ignore Program 3 and PID 120 (0x78) errors in the Navigation view because these are caused by the original test40.TRP file.

---

33. Press the **Stop** button on the MTX100B.
34. Close the TS Compliance Analyzer window.

### External Clock/Reference and External Trigger Inputs

This test verifies that the external clock/reference input (Clock/Ref In) and external trigger input (Trig In/Out) on the MTX100B are functioning correctly.

<b>Equipment required</b>	MPEG analyzer Function generator Two 50 $\Omega$ BNC cables Parallel interface cable test64.TRP file
---------------------------	--

1. Use a 50  $\Omega$  BNC cable to connect the Clock/Ref In connector on the MTX100B to the Ch1 connector on the function generator. See Figure 3-4.
2. Use the 50  $\Omega$  BNC cable to connect the Trig In/Out connector on the MTX100B to the Ch2 connector on the function generator. See Figure 3-4.
3. Use the parallel interface cable to connect the SPI In/Out connector on the MTX100B to the DVB/SPI In connector on the MPEG analyzer. See Figure 3-4.

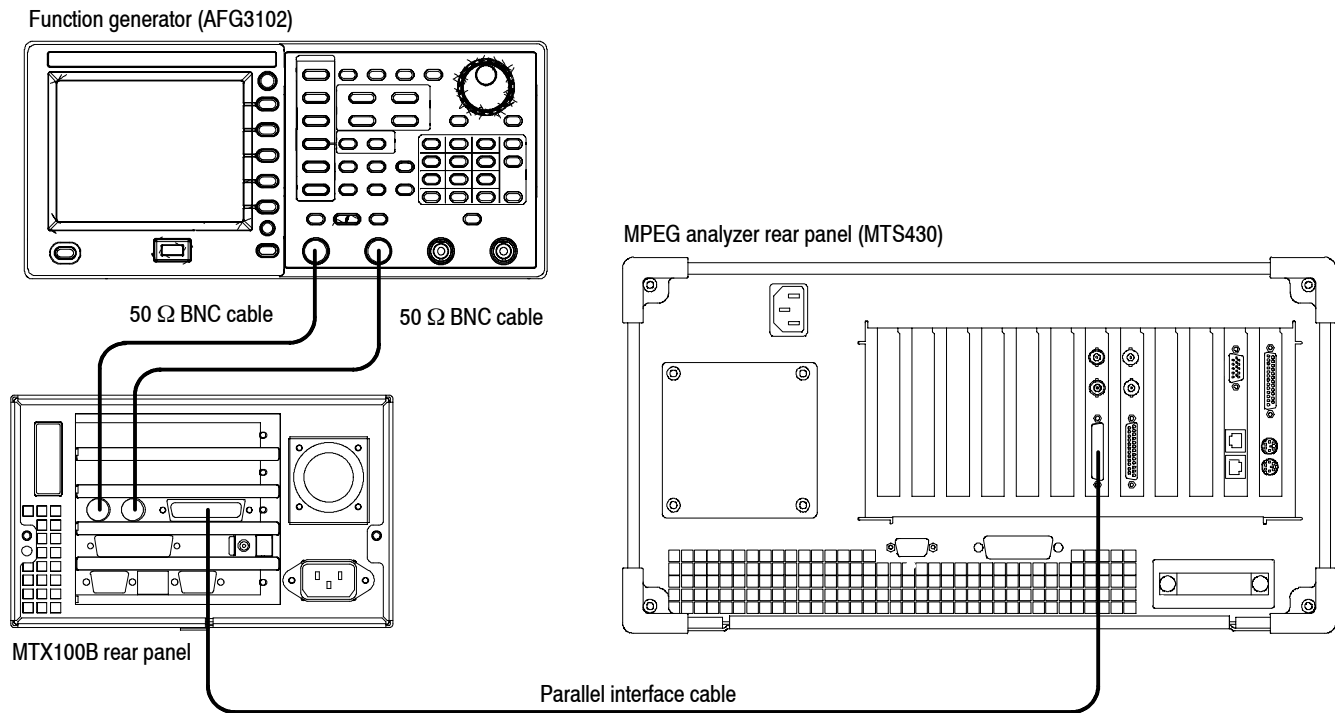

**Figure 3-4: Equipment connections for verifying the external clock/reference and trigger inputs**

4. Set the function generator settings as indicated below:

**Ch 1 output**

Function . . . . . Square  
 Run Mode . . . . . Continuous  
 Frequency . . . . . 10 MHz  
 Output Amplitude . . . . . 0.5 V  
 Output Offset . . . . . 2.0 V

**Ch 2 output**

Function . . . . . Arb (Edit: Point Number: 100,  
 All Data: 16382)  
 Run Mode . . . . . Continuous  
 Output Menu . . . . . Load Impedance: 1 kΩ  
 Output Amplitude . . . . . 1.75 V  
 Output Offset . . . . . 0.875 V

5. Press the **On** button of the Ch1 output on the function generator.
6. Open the **test64.TRP** file on the MTX100B.
  - a. Select **File > Open** in the Play screen to open the Select File dialog box.
  - b. In the dialog box, select the **test64.TRP** file.

7. Select **Play > Update > On**.
8. Select **Play > Clock** to open the **Clock** dialog box.
9. In the dialog box, select **ExtRef 10**.
10. Press the **Play/Pause** button on the MTX100B to start playing the test64.TRP file.
11. Verify that PLL unlock error does not occur on the MTX100B.
12. Start the **TS Compliance Analyzer** on the MPEG analyzer.
13. In the **Open Transport Stream** dialog box, select **Real-time Analysis**, and then make the following settings:
  - Interfaces . . . . . DVB Parallel
  - Interface Settings . . . . Time Stamping
14. Verify that the hierarchic view is displayed on the MPEG analyzer screen and that no error messages appear. In addition, verify that the data rate is **64 Mbps** and the packet size is **188** bytes.

---

**NOTE.** Ignore Program 3 and PID 120 (0x78) errors in the Navigation view because these are caused by the original test40.TRP file.

---

15. Change the clock source setting on the MTX100B and output frequency setting on the function generator with the following and then repeat step 14.

<b>Clock source setting (MTX100B)</b>	<b>Output frequency setting (function generator)</b>
ExtRef 27	27 MHz
Ext Ref 8.126984 MHz	8.126984 MHz
Ext P Clk	8 MHz

16. Change the output frequency of the function generator to 32 MHz.
17. Select **Play > Clock** on the MTX100B to open the **Clock** dialog box.
18. In the dialog box, select **Ext S Clk**.
19. Repeat step 14 and verify that all items in the **Priority 1** row are green.

---

**NOTE.** Ignore 2.3.a PCR Repetition and 2.5 PTS errors in the Priority 2 row.

---

20. Press the **Stop** button on the MTX100B to stop the stream output.

21. Select **Play > Clock** on the MTX100B to open the **Clock** dialog box.
22. In the dialog box, select **Internal**.
23. Press the **On** button of the Ch1 output on the function generator to stop the signal output.
24. Press the **On** button of the Ch2 output on the function generator to start the signal output.
25. Select **Play > Others** on the MTX100B to open the **Others** dialog box.
26. In the dialog box, set **Ext Play Start** to **Rise**.
27. Verify that the MTX100B starts playing when the **Output** menu is set to **Invert** on the function generator.
28. Press the **Stop** button on the MTX100B to stop the stream output.
29. Press the **On** button of the Ch2 output on the function generator to stop the signal output.
30. Return **Ext Play Start** to **Off** on the MTX100B.
31. Disconnect all cables from the MTX100B, function generator, and MPEG analyzer.



**IEEE1394b Interface**

This test verifies that the IEEE1394b interface is functioning correctly.

<b>Equipment required</b>	IEEE1394b hard disk drive IEEE1394b cable (9 pin-9 pin) test40.TRP file
---------------------------	---

1. Use the IEEE1394b cable to connect the IEEE1394b connector on the MTX100B to the IEEE1394b hard disk drive. See Figure 3-5.

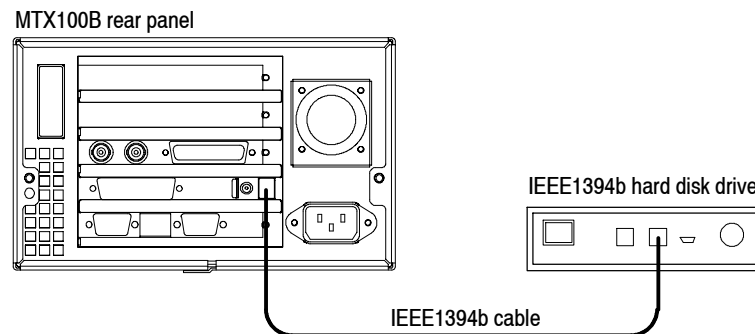

**Figure 3-5: Equipment connection for verifying the IEEE1394b interface**

2. Select **Play > Minimize** to minimize the MTX100B application.
3. Power on the IEEE1394b hard disk drive.
4. Double-click the **My Computer** icon on the Windows desktop to open the My Computer window.
5. In the Window, verify that the hard disk drive is recognized as the **F:** (or **G:**) drive.
6. Use the windows file copy operation to copy the **test40.TRP** file on the **D:** drive to **F:** (or **G:**) drive.
7. Verify that the test40.TRP file is copied to the F: (or G:) drive correctly.
8. Delete the test40.TRP file from the F: (or G:) drive.
9. Power off the IEEE1394b hard disk drive.

**ASI Interface (Option 01 Only)**

This test verifies that transport stream data is correctly output from and is recorded through the ASI interface on the MTX100B Option 01.

<b>Equipment required</b>	MPEG analyzer Oscilloscope Two 75 $\Omega$ BNC cable 75 $\Omega$ signal adapter test40.TRP file
---------------------------	---

**Checking the Output Signal.**

1. Use a 75  $\Omega$  BNC cable and the 75  $\Omega$  signal adapter to connect the ASI Out 1 connector on the MTX100B Option 01 to the oscilloscope CH1 input. See Figure 3-6.

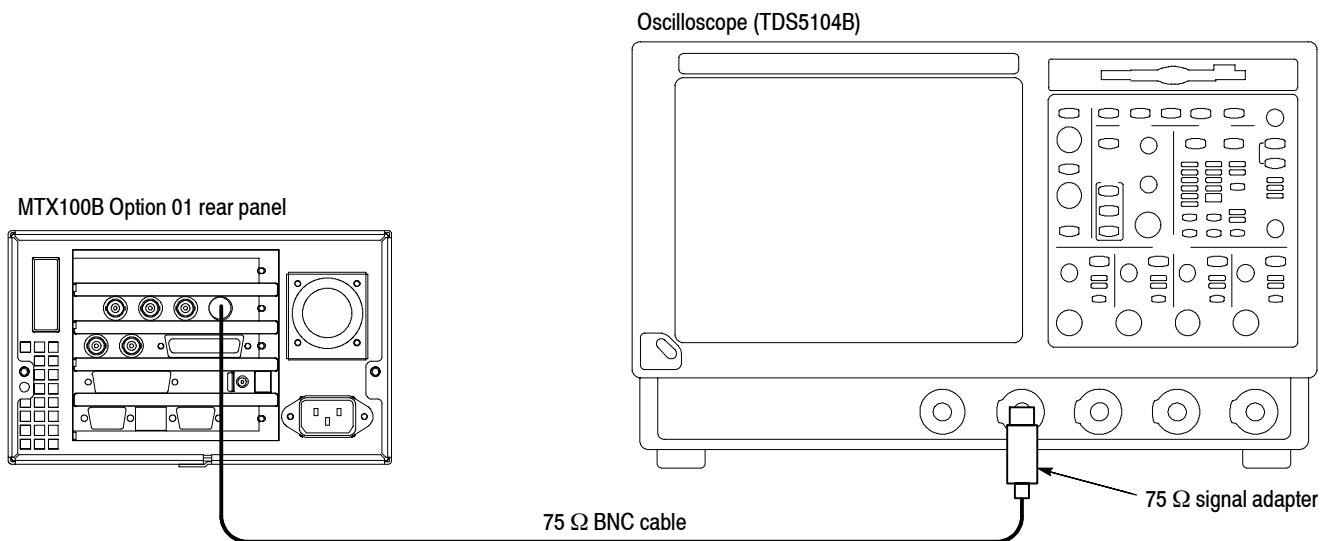

**Figure 3-6: Equipment connection for verifying the output signal-ASI interface**

2. Set the oscilloscope settings as indicated below:

Vertical scale . . . . . 200 mV/div  
Input impedance . . . . . 50  $\Omega$   
Horizontal scale . . . . . 1.25 ns/div  
Trigger position . . . . . 50%  
Acquire mode . . . . . Average 32  
Trigger mode . . . . . AUTO  
Trigger source . . . . . CH1  
Trigger level . . . . . 0 V  
Trigger slope . . . . . Rising Edge  
Input coupling . . . . . DC  
Measure . . . . . Amplitude, Rise Time, Fall Time  
Ref Level . . . . . High Ref 80%, Low Ref 20%  
Gating . . . . . Cursor Curs1 Pos1: -2.5 ns/Curs2: 2.75 ns

3. Open the test40.TRP file on the MTX100B Option 01.
  - a. Select **File > Open** in the Play screen to open the **Select File** dialog box.
  - b. In the dialog box, select the **test40.TRP** file.
4. Press the **Play/Pause** button to start playing the test40.TRP file.
5. Use the oscilloscope to measure that the amplitude, rise and fall times are as follows:

Amplitude: 720 mV to 880 mV  
Rise and fall time:  $\leq 1.2$  ns
6. Move the BNC cable connection from the ASI Out 1 connector to the ASI Out 2 connector on the MTX100B Option 01 and then repeat step 5.
7. Move the BNC cable connection from ASI Out 2 connector to the through output of the ASI In connector.
8. Connect the ASI Out 1 connector to the ASI In connector on the MTX100B Option 01 using the 75  $\Omega$  BNC cable.
9. Select **ASI/IF > Through Out > On** on the MTX100B Option 01 and then repeat step 5.

**Checking the Play Operation.**

10. Disconnect the BNC cable from the 75 Ω signal adapter on the oscilloscope, and then connect the cable to the ASI/SMPTE In connector on the MPEG analyzer. See Figure 3-7.

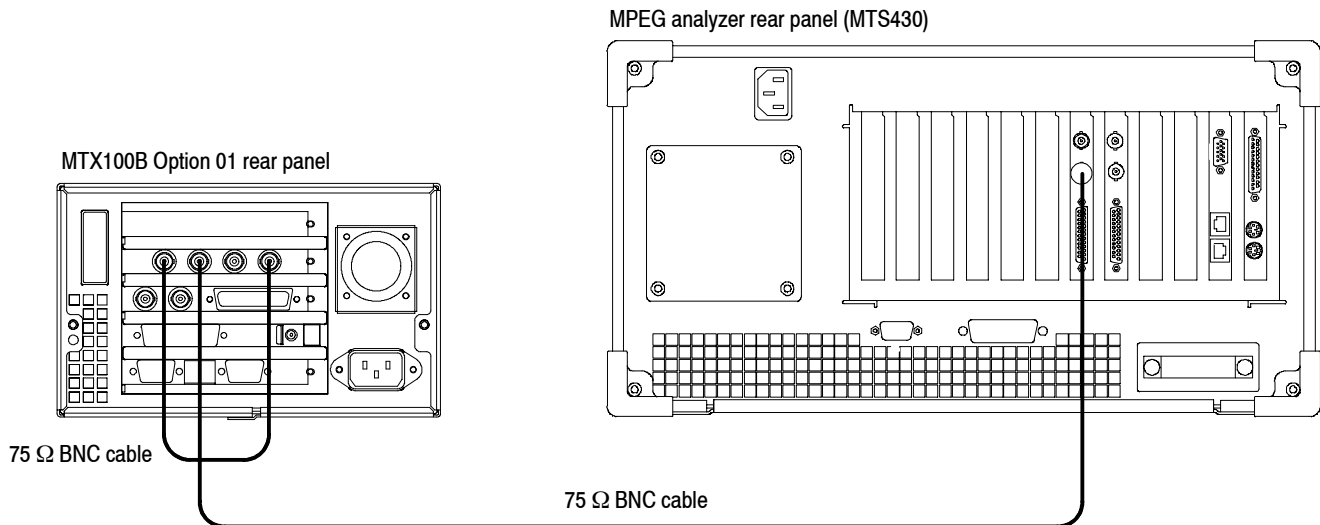

**Figure 3-7: Equipment connections for verifying the play operation- ASI interface**

11. Start the **MPEG Player** application on the MPEG analyzer.
12. Set the application to the **Record** mode.
13. Set the MPEG analyzer settings as indicated bellow:

**Record menu**

Source . . . . . SPI/ASI/310M  
 Target . . . . . RAM, Record Size: 100 MB

**SPI/ASI/310M menu**

Input Port . . . . . BNC  
 BNC Port . . . . . ASI

**File menu**

Save Mode . . . . . Overwrite  
 Save . . . . . E:\MTXRTX\_Test streams\Record\_Files\  
 ASI214Mbps.trp

14. In the **Play** menu on the MTX100B Option 01, make the following settings:
  - Clock . . . . . Data Rate: 214 Mbps
  - Update . . . . . Off
  - Source . . . . . RAM
15. Select **ASI I/F > Through Out > On**.
16. Press the **Play/Pause** button on the MTX100B Option 01 to start playing the test40.TRP.
17. Verify that the hierarchic view is displayed on the MPEG analyzer screen. In addition, verify that the bit rate is **214 Mbps** and the packet size is **188** bytes.
18. Click the **Record** button on the MPEG Player application to record the file.
19. After recording is completed, press the **Stop** button on the MTX100B Option 01.
20. Disconnect the 75  $\Omega$  BNC cables from the MTX100B Option 01 and MPEG analyzer.

#### Checking the Record Operation.

21. Use a 75  $\Omega$  BNC cable to connect the ASI In connector on the MTX100B Option 01 to the ASI/SMPTE Out connector on the MPEG analyzer. See Figure 3-8.

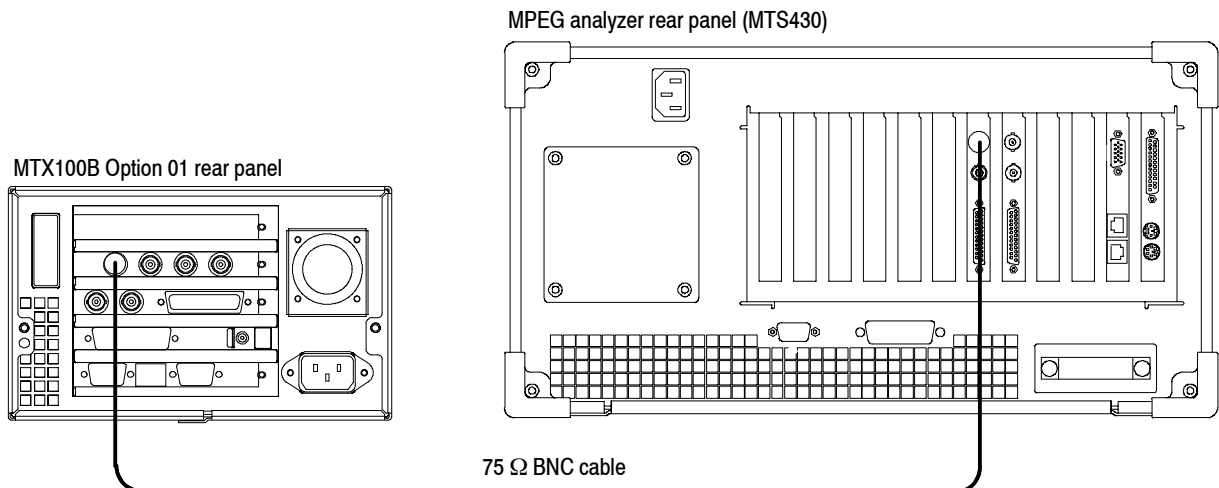

**Figure 3-8: Equipment connection for verifying the record operation-ASI interface**

22. Press the **Record** button on the MTX100B Option 01 to display the Record screen.

23. On the MTX100B Option 01, make the following settings:

**Record menu**

Source . . . . . ASI  
Record size . . . . . 100 MB  
Target . . . . . RAM

**File menu**

Save Mode . . . . . Overwrite  
Save . . . . . D:\Record\_Files\ASI214Mbps.trp

24. Set the MPEG analyzer to the Play mode.

25. Select **File > Open** on the MPEG analyzer to display the Open dialog box.

26. In the dialog box, navigate to the **E:\MTXRTX\_Test Streams\  
Record\_Files** directory, and then select the **ASI214Mbps.trp** file.

27. Set the following settings on the MPEG analyzer:

**Play menu**

Clock . . . . . Data Rate: 214 Mbps  
Update . . . . . Off  
Source . . . . . RAM

**SPI/ASI/310M menu**

BNC Port . . . . . ASI  
Through Out . . . . . Off

28. Click the **Play** button on the MPEG analyzer to start playing the ASI214Mbps.trp file.

29. Verify that the hierarchic view is displayed on the MTX100B Option 01 screen. In addition, verify that the bit rate is **214 Mbps** and packet size is **188** bytes.

30. Press the **Record** button on the MTX100B Option 01 to record the file.

31. After recording is completed, click the **Stop** button on the MPEG analyzer.

32. Exit the MPEG Player application on the MPEG analyzer.

33. Disconnect the 75  $\Omega$  BNC cable from the MTX100B Option 01 and MPEG analyzer.

**Checking the Recorded File.**

34. Use the 75  $\Omega$  BNC cable to connect the ASI Out 2 connector on the MTX100B Option 01 to the ASI/SMPTE In connector on the MPEG test system. See Figure 3-9.

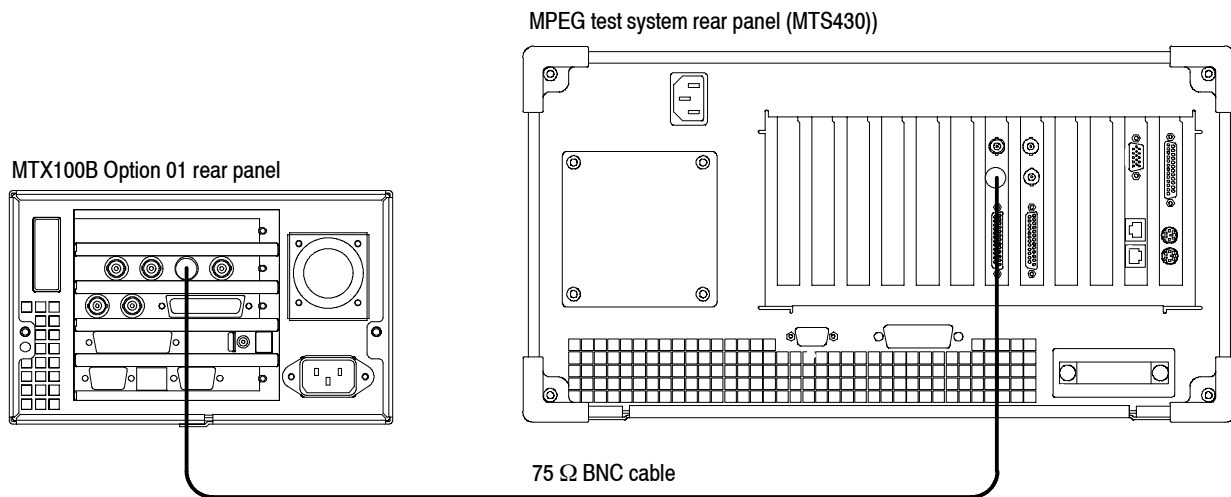

**Figure 3-9: Equipment connection for verifying the recorded file-ASI interface**

35. Press the **Play/Pause** button on the MTX100B Option 01 to display the Play screen.
36. Select **Play > Update > On**.
37. Open the ASI214Mbps file on the MTX100B Option 01.
- Select **File > Open** to open the **Select File** dialog box.
  - In the dialog box, navigate to the **D:\Record\_Files** directory, and then select the **ASI214Mbps.trp** file.
38. Press the **Play/Pause** button to start playing the file.
39. Start the **TS Compliance Analyzer** on the MPEG analyzer.
40. In the **Open Transport Stream** dialog box, select **Real-time Analysis**, and then make the following settings
- Interfaces . . . . . ASI  
Interface Settings . . . . Time Stamping
41. Verify that the hierarchic view is displayed on the MPEG analyzer screen and that no error messages appear. In addition, verify that the bit rate is **40 Mbps** and that the transport stream packet size is **188 bytes**.

---

**NOTE.** Ignore Program 3 and PID 120 (0x78) errors in the Navigation view because these are caused by the original test40.TRP file.

---

42. Press the **Stop** button on the MTX100B Option 01 to stop the stream output.
43. Disconnect the 75  $\Omega$  BNC cable from the MTX100B Option 01 and MPEG analyzer.

**Universal Parallel/Serial Interface (Option 02 Only)**

This test verifies that transport stream data is correctly output from and is recorded through the Universal Parallel/Serial interface on the MTX100B Option 02.

<b>Equipment required</b>	MPEG analyzer MPEG recorder and player (MTX100A(B) Option 02) Oscilloscope Probe 50 $\Omega$ BNC cable Parallel interface cable test40.TRP file
---------------------------	---

**Checking the Output Signals.**

1. Connect the probe to the oscilloscope CH1 input. See Figure 3-10 on page 3-21.



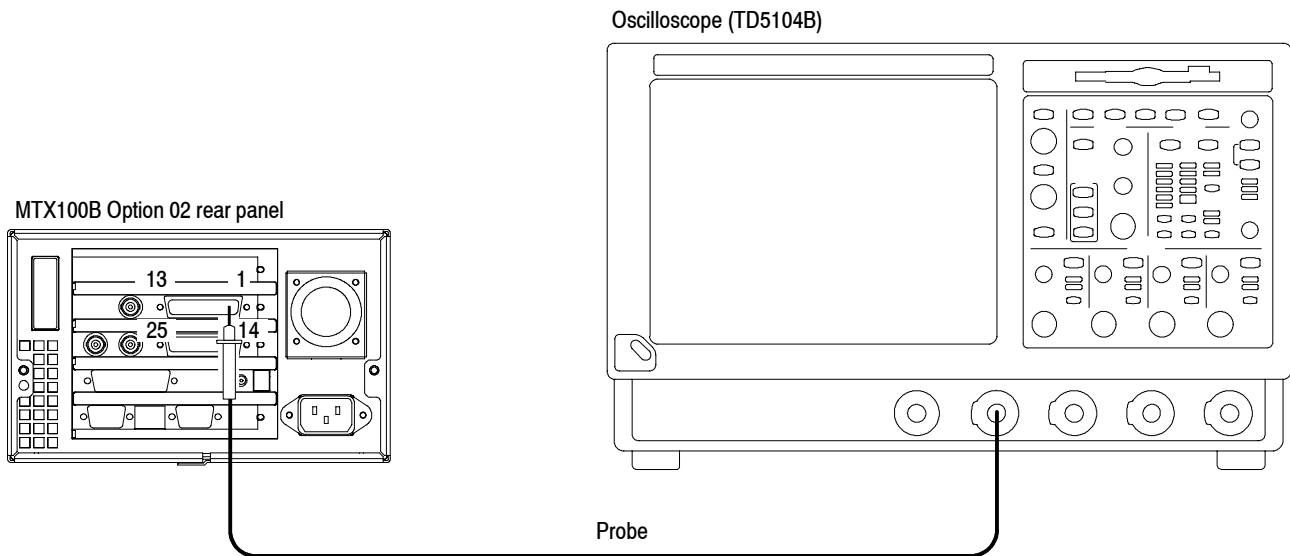

**Figure 3-10: Equipment connection for verifying the output signals- universal parallel/serial interface**

2. Set the oscilloscope settings as indicated below:

Vertical scale . . . . . 500 mV/div  
 Vertical offset . . . . . -1.3 V  
 Horizontal scale . . . . . 400 ns/div  
 Horizontal position . . . Center  
 Trigger source . . . . . CH1  
 Trigger level . . . . . -1.3 V (at ECL level)  
   1.4 V (at TTL level)  
   1.2 V (at LVDS level)

3. Press the **Play/Pause** button on the MTX100B Option 02 to display the Play screen.
4. Open the **test40.TRP** file on the MTX100B Option 02.
  - a. Select **File > Open** to open the **Select File** dialog box.
  - b. In the dialog box, select the **test40.TRP** file.
5. Select **Play > Clock** to open the **Clock** dialog box.
6. In the dialog box, set **Data Rate** to **10 Mbps**.
7. Select **Univ I/F > Level > ECL**.
8. Press the **Play/Pause** button to start playing the test40.TRP file.
9. Attach the probe tip to **pin 1** of the Universal In/Out connector on the MTX100B Option 02.

10. Use the oscilloscope to measure that the ECL high and low levels of pin 1 are as follows:

High level: -0.5 V

Low level: -2.1 V

11. Move the probe tip attachment from pin 1 to pin 14, and measure that the ECL high and low levels correspond to the values shown in Table 3-3.
12. Repeat step 11 for all other pins.

**Table 3-3: Output level of each connector pin**

Pin number	ECL		TTL		LVDS	
	High	Low	High	Low	High	Low
1, 14 (CLK)	-0.5 V	-2.1 V	3.3 V	0.0 V	1.6 V	0.8 V
3, 16 (DATA 7)	-0.5 V	-2.1 V	3.3 V	0.0 V	1.6 V	0.8 V
4, 17 (DATA 6)	-0.5 V	-2.1 V	3.3 V	0.0 V	1.6 V	0.8 V
5, 18 (DATA 5)	-0.5 V	-2.1 V	3.3 V	0.0 V	1.6 V	0.8 V
6, 19 (DATA 4)	-0.5 V	-2.1 V	3.3 V	0.0 V	1.6 V	0.8 V
7, 20 (DATA 3)	-0.5 V	-2.1 V	3.3 V	0.0 V	1.6 V	0.8 V
8, 21 (DATA 2)	-0.5 V	-2.1 V	3.3 V	0.1 V	1.6 V	0.8 V
9, 22 (DATA 1)	-0.5 V	-2.1 V	3.3 V	0.0 V	1.6 V	0.8 V
10, 23 (DATA 0)	-0.5 V	-2.1 V	3.3 V	0.0 V	1.6 V	0.8 V
11 (DVALID)	-0.5 V	-----	3.3 V	-----	1.6 V	-----
14 ( $\overline{\text{DVALID}}$ )	-----	-2.1 V	-----	0.0 V	-----	0.8 V
12, 25 (PSYNC)	-0.5 V	-2.1 V	3.3 V	0.0 V	1.6 V	0.8 V

13. Select **Univ I/F > Level > TTL** on the MTX100B Option 02.
14. Use the oscilloscope to measure that TTL High and Low levels of all the pins correspond to the values shown in Table 3-3.
15. Select **Univ I/F > Level > LVDS** on the MTX100B Option 02.
16. Use the oscilloscope to measure that LVDS High and Low levels of all the pins correspond to the values shown in Table 3-3.

**Checking the Play Operation (Parallel Mode).**

1. Use the parallel interface cable to connect the Universal In/Out connector on the MTX100B Option 02 to the Universal In/Out connector on the MPEG recorder and player. See Figure 3-11.

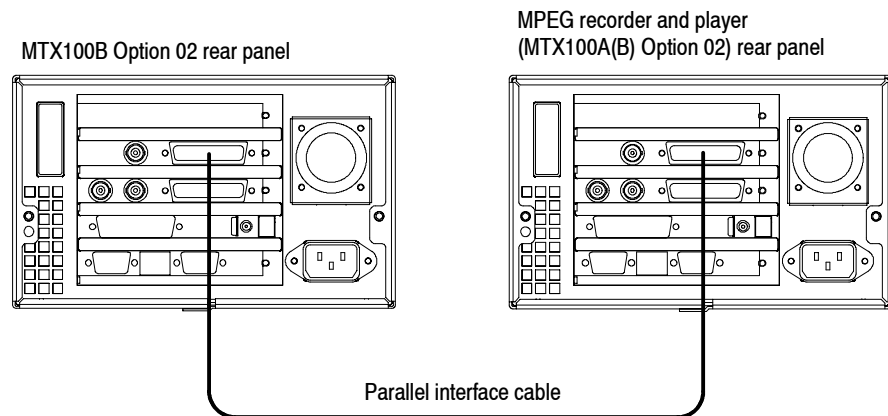

**Figure 3-11: Equipment connection for verifying the play operation- universal parallel/serial interface**

2. Press the **Play/Pause** button on the MTX100B Option 02 to display the Play screen.
3. On the MTX100B Option 02, make the following settings:

**Play menu**

Data rate . . . . . 214 Mbps  
 Update . . . . . Off  
 Source . . . . . RAM

**Univ I/F menu**

Level . . . . . LVDS  
 Format . . . . . Parallel

4. Press the **Record** button on the MPEG recorder and player to display the Record screen.
5. On the MPEG recorder and player, make the following settings:

**Record menu**

Source . . . . . Univ I/F  
 Record size . . . . . 100 MB  
 Target . . . . . RAM

**Univ I/F menu**

Level . . . . . LVDS  
Format . . . . . Parallel  
Receive . . . . . Differential  
Termination . . . . . On

**File menu**

Save Mode . . . . . Overwrite  
Save . . . . . E:\Record\_Files\Parallel\_LVDS.trp

6. Press the **Play/Pause** button on the MTX100B Option 02 to start playing the test40.TRP file.
7. Verify that the hierarchic view is displayed on the MPEG recorder and player screen. In addition, verify that the bit rate display is **214 Mbps** and packet size is **188** bytes.
8. Press the **Record** button on the MPEG recorder and player to record the file.
9. After recording is completed, press the **Stop** button on the MTX100B Option 02.

**Checking the Play Operation (Serial Mode).**

10. Select **Play > Clock** on the MTX100B Option 02 to open the **Clock** dialog box.
11. In the dialog box, set **Data Rate** to **40 Mbps**.
12. Select **Univ I/F > Format > Serial** on the MTX100B Option 02.
13. Press the **Record** button on the MPEG recorder and player to display the Record screen.
14. On the MPEG recorder and player, make the following settings:

**Univ I/F menu**

Format . . . . . Serial

**File menu**

Save . . . . . D:\Record\_Files\Serial\_LVDS.trp

15. Press the **Play/Pause** button on the MTX100B Option 02 to start playing the test40.TRP file.
16. Verify that the hierarchic view is displayed on the MPEG recorder and player screen. In addition, verify that the bit rate display is **40 Mbps** and the packet size is **188** bytes.
17. Press the **Record** button on the MPEG recorder and player to record the file.

18. After recording is completed, press the **Stop** button on the MTX100B Option 02.

#### Checking the Record Operation (Parallel Mode).

19. Press the **Record** button on the MTX100B Option 02 to display the Record screen.
20. On the MTX100B Option 02, make the following settings:

##### Record menu

Source . . . . . Univ I/F  
Record size . . . . . 100 MB  
Target . . . . . RAM

##### Univ I/F menu

Level . . . . . LVDS  
Format . . . . . Parallel  
Receive . . . . . Differential  
Termination . . . . . On

##### File menu

Save Mode . . . . . Overwrite  
Save . . . . . D:\Record\_Files\Parallel\_LVDS.trp

21. Press the **Play/Pause** button on the MPEG recorder and player to display the Play screen.
22. Open the **Parallel\_LVDS.trp** file on the MPEG recorder and player.
  - a. Select **File > Open** to open the **Select File** dialog box.
  - b. In the dialog box, navigate to the **E:\Record\_Files** directory, and then select the **Parallel\_LVDS.trp** file.
23. On the MPEG recorder and player, make the following settings:

##### Play menu

Data rate . . . . . 214 Mbps  
Update . . . . . Off  
Source . . . . . RAM

24. Press the **Play/Pause** button on the MPEG recorder and player to start playing the file.
25. Verify that the hierarchic view is displayed on the MTX100B Option 02 screen. In addition, verify that the bit rate display is **214 Mbps** and the packet size is **188** bytes.
26. Press the **Record** button on the MTX100B Option 02 to record the file.

27. After recording is completed, press the **Stop** button on the MPEG recorder and player.

**Checking the Record Operation (Serial Mode).**

28. On the MTX100B Option 02, make the following settings:

**Univ I/F menu**  
Format . . . . . Serial

**File menu**  
Save . . . . . D:\Record\_Files\Serial\_LVDS.trp

29. Open the **Serial\_LVDS.trp** file on the MPEG recorder and player.
  - a. Select **File > Open** to open the Select File dialog box.
  - b. In the dialog box, navigate to the **D:\Record\_Files** directory, and then select the **Serial\_LVDS.trp** file.
30. Select **Play > Clock** on the MPEG recorder and player to open the **Clock** dialog box.
31. In the dialog box, set **Data Rate** to **40 Mbps**.
32. Press the **Play/Pause** button on the MPEG recorder and player to start playing the file.
33. Verify that the hierarchic view is displayed on the MTX100B Option 02 screen. In addition, verify that the bit rate display is **40 Mbps** and the packet size is **188** bytes.
34. Press the **Record** button on the MTX100B Option 02 to record the file.
35. After recording is completed, press the **Stop** button on the MPEG recorder and player.

**Checking signal acquisition for ECL and TTL Levels.**

36. On the MTX100B Option 02, make the following settings:

**Univ I/F menu**  
Level . . . . . ECL  
Format . . . . . Parallel

37. Open the **test40.TRP** file on the MPEG recorder and player.
  - a. Select **File > Open** to open the Select File dialog box.
  - b. In the dialog box, navigate to the **E:** drive, and then select the **test40.TRP** file.

38. On the MPEG recorder and player, make the following settings:

**Play menu**

Clock . . . . . Data Rate: 214 Mbps  
Update . . . . . Off

**Univ/I/F menu**

Level . . . . . ECL  
Format . . . . . Parallel  
Receive . . . . . Differential

39. Press the **Play/Pause** button on the MPEG recorder and player to start playing the test40.TRP file.
40. Verify that no **Non-TS** and **No Signal** messages appear on the MTX100B Option 02 screen. In addition, the hierarchic view and the bit rate are displayed correctly (214 Mbps and 188).
41. Select **Univ I/F > Receive > Single** on the MTX100B Option 02, and then repeat step 40.
42. Select **Univ I/F > Level > TTL** on the MPEG recorder and player.
43. Select **Level > TTL** and **Receive > Differential** in the **Univ I/F** menu on the MTX100B Option 02, and then repeat step 40.
44. Select **Univ I/F > Receive > Single** on the MTX100B Option 02, and then repeat step 40.
45. On the MTX100B Option 02, make the following settings:

**Univ I/F menu**

Level . . . . . ECL  
Format . . . . . Serial  
Receive . . . . . Differential

46. On the MPEG recorder and player, make the following settings:

**Play menu**

Clock . . . . . Data Rate: 40 Mbps  
Receive . . . . . Differential

**Univ I/F menu**

Format . . . . . Serial  
Receive . . . . . Differential

47. Press the **Play/Pause** button on the MPEG recorder and player to start playing the file.
48. Repeat step 40.

49. Select **Univ I/F > Receive > Single** on the MTX100B Option 02, and then repeat step 40.
50. Select **Univ I/F > Level > TTL** on the MPEG recorder and player.
51. Select **Level > TTL** and **Receive > Differential** from the **Univ I/F** menu on the MTX100B Option 02, and then repeat step 40.
52. Select **Univ I/F > Receive > Single** on the MTX100B Option 02, and then repeat step 40.
53. Press the **Stop** button on the MPEG recorder and player to stop the stream output.
54. Disconnect the parallel interface cable from the MTX100B Option 02 and MPEG recorder and player.

**Checking the Recorded File.**

55. Use the parallel interface cable to connect the Universal In/Out connector on the MTX100B Option 02 to the DVB/SPI In connector on the MPEG test system. See Figure 3-12.

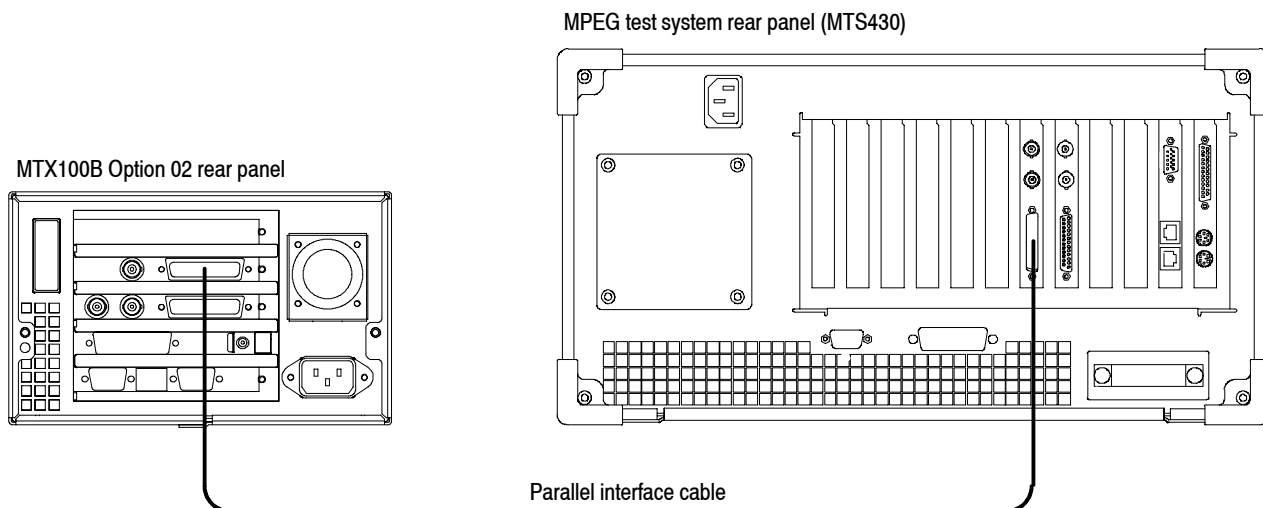

**Figure 3-12: Equipment connection for verifying the recorded file-universal parallel/serial interface**

56. Press the **Play/Pause** button on the MTX100B Option 02 to display the Play screen.
57. Select **Play > Update > On**.
58. Select **Univ I/F > Level > LVDS**.



59. Select **Univ I/F > Format > Parallel**.
60. Open the **Parallel\_LVDS.trp** file on the MTX100B Option 02.
  - a. Select **File > Open** to open the **Select File** dialog box.
  - b. In the dialog box, navigate to the **D:\Record\_Files** directory, and then select the **Parallel\_LVDS.trp** file.
61. Press the **Play/Pause** button on the MTX100B Option 02 to start playing the file.
62. Start the **TS Compliance Analyzer** on the MPEG analyzer.
63. In the **Open Transport Stream** dialog box, select **Real-time Analysis**, and then make the following settings:
  - Interfaces . . . . . DVB Parallel
  - Interface Settings . . . . Time Stamping
64. Verify that the hierarchic view is displayed on the MPEG analyzer screen and that no error messages appear. In addition, verify that the bit rate is **40 Mbps** and that the transport stream packet size is **188** bytes.

---

**NOTE.** Ignore Program 3 and PID 120 (0x78) errors in the hierarchical view because these are caused by the original test40.TRP file.

---

65. Press the **Stop** button on the MTX100B Option 02 to stop the stream output.
66. Open the **Serial\_LVDS.trp** file on the MTX100B Option 02.
  - a. Select **File > Open** to open the Select File dialog box.
  - b. In the dialog box, navigate to the **D:\Record\_Files** directory, and then select the **Serial\_LVDS.trp** file.
67. Press the **Play/Pause** button on the MTX100B Option 02 to start playing the file.
68. Restart analysis on the MPEG analyzer.
69. Repeat steps 64 and 65.
70. Disconnect the parallel interface cable from the MTX100B Option 02 and the MPEG analyzer.

**Checking the Event Output.**

71. Use the 50 Ω BNC cable to connect the Event Out connector on the MTX100B Option 02 to the oscilloscope CH1 input. See Figure 3-13.

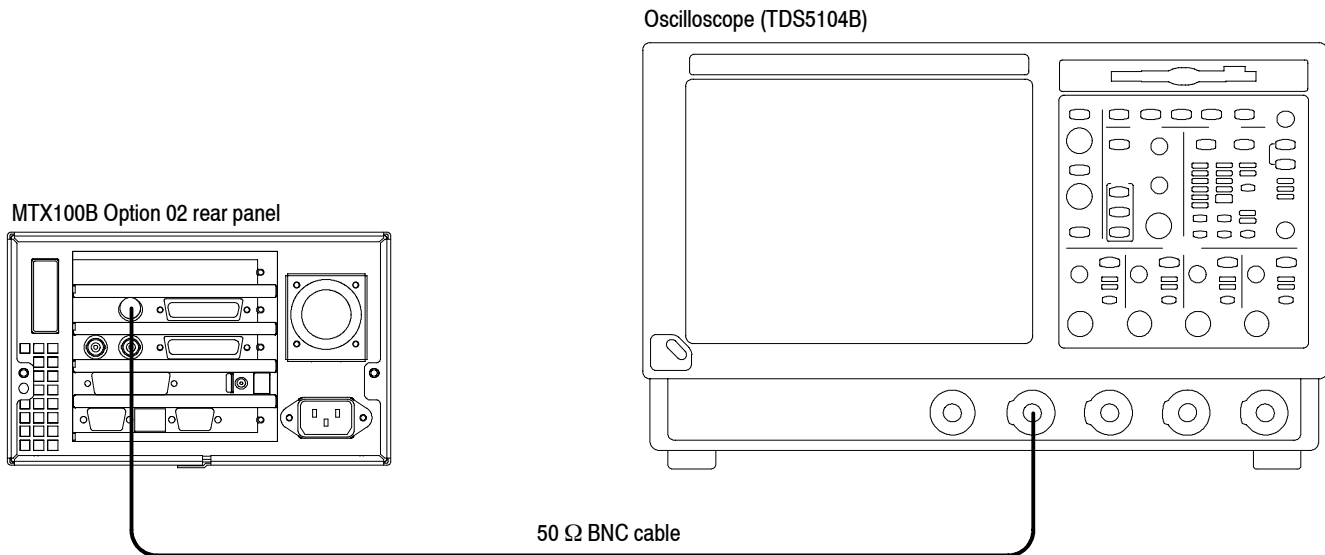

**Figure 3-13: Equipment connection for verifying the Event output**

72. Set the oscilloscope settings as indicated below:

Vertical scale . . . . . 1 V/div  
 Horizontal scale . . . . . 80 ns/div  
 Horizontal position . . . Center  
 Acquire mode . . . . . Average 16  
 Trigger level . . . . . 1.20 V  
 Trigger source . . . . . CH1  
 Trigger position5 . . . . . 0 %  
 Trigger slope . . . . . Rising Edge  
 Trigger mode . . . . . AUTO  
 Input coupling . . . . . DC  
 Input impedance . . . . . 1 MΩ  
 Measure . . . . . High Level, Low Level

73. Open the **test40.TRP** file on the MTX100B Option 02.
- a. Select **File > Open** in the Play screen to open the **Select File** dialog box.
  - b. In the dialog box, select the **test40.TRP** file.
74. Press the **Play/Pause** button on the MTX100B Option 02 to start playing the test40.TRP file.

75. Use the oscilloscope to measure that the high and low levels of the Event output are as follows:

High level: > 2.4 V

Low level: < 0.4 V

76. Press the **Stop** button on the MTX100B Option 02 to stop the stream output.

### IEEE1394/ASI Interface (Option 05 Only)

This test verifies that transport stream data is correctly output from and is recorded through the IEEE1394/ASI interface on the MTX100B Option 05.

<b>Equipment required</b>	MPEG analyzer Oscilloscope D-VHS digital recorder Video monitor 75 $\Omega$ BNC cable IEEE1394 cable (4 pin-4 pin) 75 $\Omega$ signal adapter RCA(Ma)-to-BNC(Fe) adapter test40.TRP file
---------------------------	--

### Checking the Output Signal.

1. Use the 75  $\Omega$  BNC cable and 75  $\Omega$  signal adapter to connect the ASI Output connector on the MTX100B Option 05 to the oscilloscope CH1 input. See Figure 3-14.

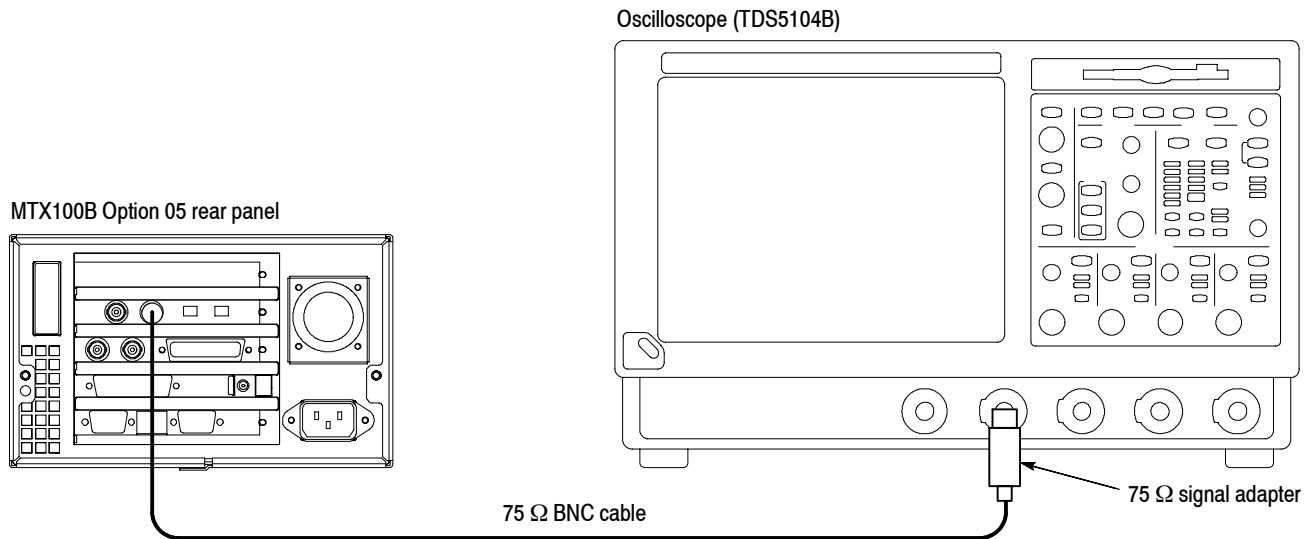

**Figure 3-14: Equipment connection for verifying the output signal-IEEE1394/ASI interface**

2. Set the oscilloscope controls as indicated below:

Vertical scale . . . . . 200 mV/div  
 Horizontal scale . . . . . 1.25 ns/div  
 Acquire mode . . . . . Average 32  
 Trigger mode . . . . . AUTO  
 Trigger level . . . . . 0 V  
 Trigger source . . . . . CH1  
 Trigger position . . . . . 50%  
 Trigger slope . . . . . Rising Edge  
 Input impedance . . . . . 50 Ω  
 Measure . . . . . Amplitude, Rise Time, Fall Time  
 Ref Level . . . . . High Ref 80%, Low Ref 20%  
 Gating . . . . . Cursor Curs1 Pos1: -2.5 ns/Curs2: 2.75 ns

3. Open the **test40.TRP** file on the MTX100B Option 05.
  - a. Select **File > Open** to open the **Select File** dialog box.
  - b. In the dialog box, select the **test40.TRP** file.
4. Press the **Play/Pause** button on the MTX100B Option 05 to start playing the test40.TRP file.
5. Use the oscilloscope to verify that the amplitude, rise and fall times are within the following range.

Amplitude: 720 mV to 880 mV  
 Rise and fall time: ≤ 1.2 ns

6. Disconnect the 75  $\Omega$  BNC cable from the MTX100B Option 05 and oscilloscope.

### Checking the Play Operation.

7. Disconnect the BNC cable from the 75  $\Omega$  signal adapter on the oscilloscope, and then connect the cable to the ASI/SMPTE In connector on the MPEG analyzer. See Figure 3-15.

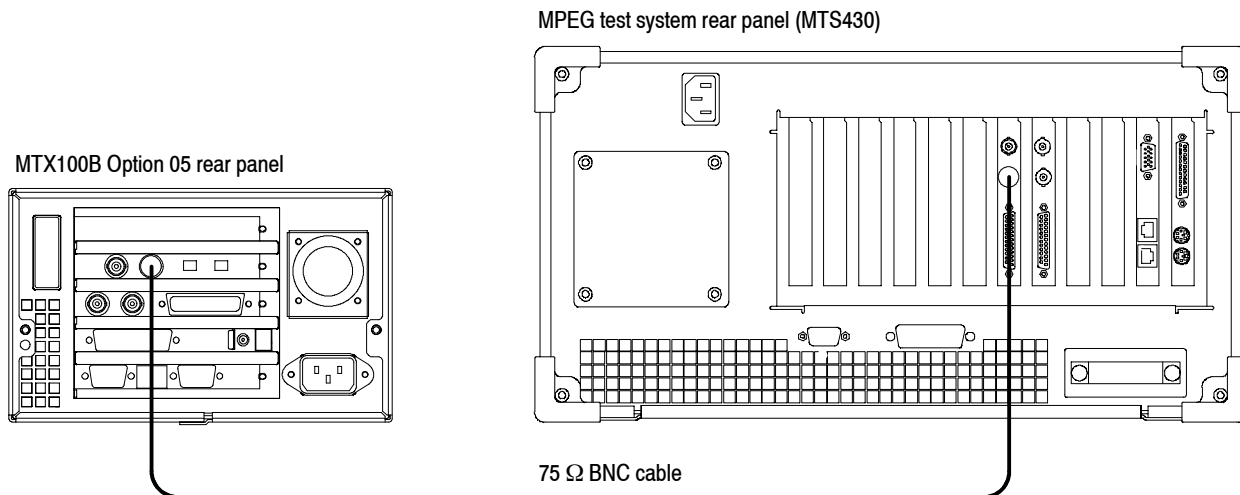

**Figure 3-15: Equipment connection for verifying the play operation-IEEE1394/ASI interface**

8. Start the **MPEG Player** application on the MPEG analyzer.
9. Set the application to the **Record** mode.
10. Set the MPEG analyzer settings as indicated below:

#### **Record**

Source . . . . . SPI/ASI/310M

Target . . . . . RAM, Record Size: 100 MB

#### **SPI/ASI/310M**

Input Port . . . . . BNC

BNC Port . . . . . ASI

#### **File**

Save Mode . . . . . Over write

Save . . . . . E:\MTXRTX\_Test streams\Record\_Files\  
ASI214Mbps.trp

11. On the MTX100B Option 05, make the following settings:

**Play menu**

Clock . . . . . Data Rate: 214 Mbps

Update . . . . . Off

Source . . . . . RAM

12. Press the **Play/Pause** button on the MTX100B Option 05 to start playing the test40.TRP.
13. Verify that the hierarchic view is displayed on the MPEG analyzer screen. In addition, verify that the bit rate is **214 Mbps** and the packet size is **188** bytes.
14. Click the **Record** button on the MPEG Player application to record the file.
15. After recording is completed, press the **Stop** button on the MTX100B Option 05.
16. Disconnect the 75  $\Omega$  BNC cable from the MTX100B Option 05 and MPEG analyzer.

**Checking the Record Operation.**

17. Use the 75  $\Omega$  BNC cable to connect the ASI In connector on the MTX100B Option 05 to the ASI/SMPTE Out connector on the MPEG analyzer. See Figure 3-16.

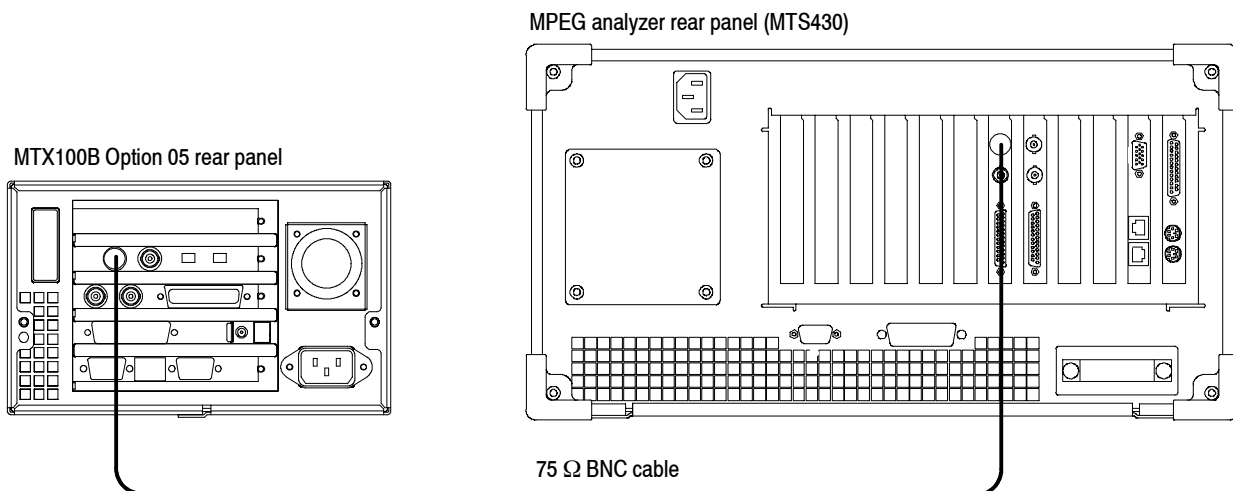
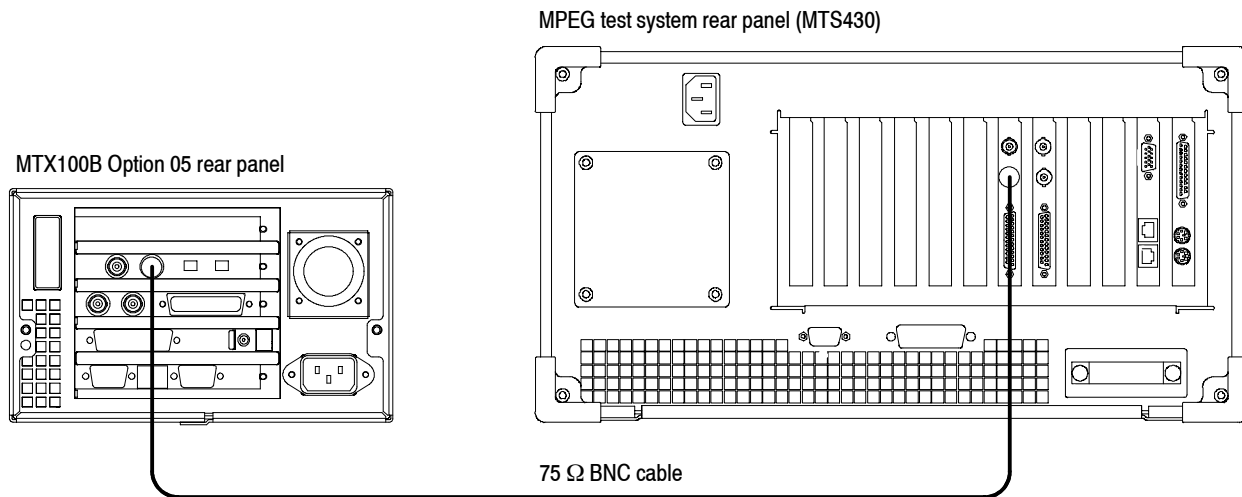

**Figure 3-16: Equipment connection for verifying the record operation-IEEE1394/ASI interface**

18. Press the **Record** button on the MTX100B Option 05 to display the Record screen.
19. On the MTX100B Option 05, make the following settings:
  - Record menu**
    - Source . . . . . ASI/1394
    - Record size . . . . . 100 MB
    - Target . . . . . RAM
  - File menu**
    - Save Mode . . . . . Over Write
    - Save . . . . . D:\Record\_Files\ASI214Mbps.trp
20. Set the MPEG analyzer to the Play mode.
21. Select **File > Open** on the MPEG analyzer to display the **Open** dialog box.
22. In the dialog box, navigate to the **E:\MTXRTX\_Test Streams\Record\_Files** directory, and then select the **ASI214Mbps.trp** file.
23. Set the following settings on the MPEG analyzer:
  - Play**
    - Clock . . . . . Data Rate: 214 Mbps
    - Update . . . . . Off
    - Source . . . . . RAM
  - SPI/ASI/310M**
    - BNC Port . . . . . ASI
    - Through Out . . . . . Off
24. Click the **Play** button on the MPEG analyzer to start playing the ASI214Mbps.trp file.
25. Verify that the hierarchic view is displayed on the MTX100B Option 05 screen. In addition, verify that the bit rate is **214 Mbps** and packet size is **188** bytes.
26. Press the **Record** button on the MTX100B Option 05 to record the file.
27. After recording is completed, click the **Stop** button on the MPEG analyzer.
28. Exit the MPEG Player application on the MPEG analyzer.
29. Disconnect the 75  $\Omega$  BNC cable from the MTX100B Option 05 and MPEG analyzer.

**Checking the Recorded File.**

30. Use the 75 Ω BNC cable to connect the ASI Output connector on the MTX100B Option 05 to the ASI/SMPTE In connector on the MPEG test system. See Figure 3-17.



**Figure 3-17: Equipment connection for verifying the recorded file- IEEE1394/ASI interface**

31. Press the **Play/Pause** button on the MTX100B Option 05 to display the Play screen.
32. Select **Play > Update > On**.
33. Open the **ASI214Mbps** file on the MTX100B Option 05.
  - a. Select **File > Open** to open the **Select File** dialog box.
  - b. In the dialog box, navigate to the **D:\Record\_Files** directory, and then select the **ASI214Mbps.trp** file.
34. Press the **Play/Pause** button on the MTX100B Option 05 to start playing the file.
35. Start the **TS Compliance Analyzer** on the MPEG analyzer.
36. In the **Open Transport Stream** dialog box, select **Real-time Analysis**, and then make the following settings
  - Interfaces . . . . . ASI
  - Interface Settings . . . . Time Stamping



37. Verify that the hierarchic view is displayed on the screen and that no error messages appear. In addition, verify that the bit rate is **40 Mbps** and that the packet size is **188** bytes.

---

**NOTE.** Ignore Program 3 and PID 120 (0x78) errors in the hierarchical view because these are caused by the original test40.TRP file.

---

38. Press the **Stop** button on the MTX100B Option 05 to stop the stream output.
39. Disconnect the 75  $\Omega$  BNC cable from the MTX100B Option 05 and MPEG analyzer.

#### **Checking the IEEE1394 Output Signal.**

1. Use the IEEE1394 cable to connect the IEEE1394 port on the MTX100B Option 05 to the i.LINK IN/OUT connector of the D-VHS digital recorder. See Figure 3-18.
2. Use the 75  $\Omega$  BNC cable and RCA(Ma)-to-BNC(Fe) adapter to connect the VIDEO OUTPUT connector on the D-VHS digital recorder to the video input on the video monitor. See Figure 3-18.

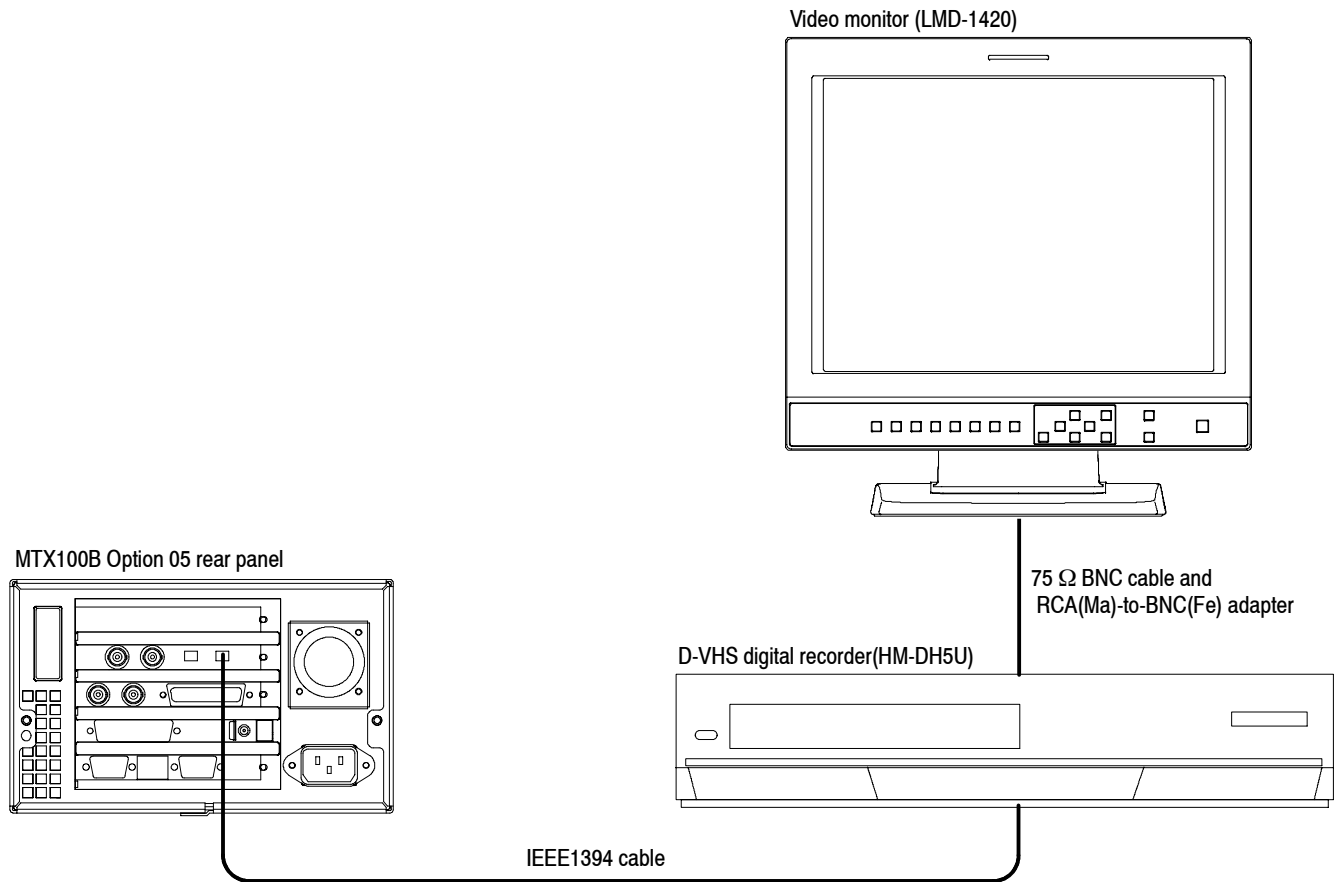

**Figure 3-18: Equipment connection for verifying the IEEE1394 output signal**

3. Make the following i.LINK setup on the D-VHS digital recorder:
  - a. Press the **MENU** button on the remote controller that is provided with the D-VHS digital recorder to display the Main Menu screen.
  - b. Press the left or right arrow button on the remote controller to move the arrow to **INITIAL SET UP**, and then press the **OK** button.
  - c. Press the left or right arrow button to move the arrow to **OTHER**, and then press the **OK** button.
  - d. Press the up or down arrow button to move the arrow to **LINK**, and then press left or right arrow button to set to **AUTO**.
  - e. Press the **MENU** button to return to Main Menu screen.
4. Press the **Play/Pause** button on the MTX100B Option 05 to display the Play screen.

5. Open the **Flower.trp** file on the MTX100B Option 05.
  - a. Select **File > Open** to open the **Select File** dialog box.
  - b. In the dialog box, navigate to the **D:\525** directory, and then select the **Flower.trp** file.
6. Select **ASI/1394 > 1394Mode > PtoP Connect** on the MTX100B Option 05 to open the **IEEE1394** dialog box.
7. In the dialog box, select **JVC HM-DH5** in the **Instrument** list box.
8. In the dialog box, select the **Connect** button, and then select the **OK** button.
9. Press the **TV/VCR CH +/-** button on the remote controller to select **I** as a recording channel.
10. Press the **Play/Pause** button on the MTX100B Option 05 to start playing the **Flower.trp** file.
11. Press the **REC** button on the D-VHS digital recorder.
12. Verify that any block noise does not appear on the video monitor.
13. After about 30 seconds recording, press the **STOP** button on the D-VHS digital recorder.
14. Press the **REW** (◀◀) button on the D-VHS digital recorder.
15. Press the **Record** button on the MTX100B Option 05 to display the Record screen.
16. Select **Record > Source > ASI/1394** on the MTX100B Option 05.
17. Select **ASI/1394 > Input Port > 1394** on the MTX100B Option 05.
18. Select **ASI/1394 > 1394 Mode > PtoP Connect** to open the **IEEE1394** dialog box.
19. In the dialog box, select the **Disconnect** button, and then select the **OK** button.
20. Select **ASI/1394 > 1394 Mode > PtoP Connect** to open the **IEEE1394** dialog box.
21. In the dialog box, select the **Connect** button, and then select the **OK** button.
22. Press the **PLAY** button on the D-VHS digital recorder.
23. Verify that correct hierarchy display appears on the MTX100B Option 05 screen.

24. Disconnect all the cables from the MTX100B Option 05, D-VHS digital recorder, and video monitor.

**SMPTE310M/ASI/SPI Interface (Option 07 Only)**

This test verifies that transport stream data is correctly output from and is recorded through the SMPTE310M/ASI/SPI interface on the MTX100B Option 07.

<b>Equipment required</b>	Oscilloscope MPEG analyzer 75 Ω precision termination 75 Ω BNC cable 75 Ω signal adapter test40.TRP file Flower.trp file
---------------------------	--

**Checking the Output Signal.**

1. Use the 75 Ω BNC cable and the 75 Ω signal adapter to connect the SMPTE310M/ASI Output connector on the MTX100B Option 07 to the oscilloscope CH1 input. See Figure 3-19 on page 3-40.

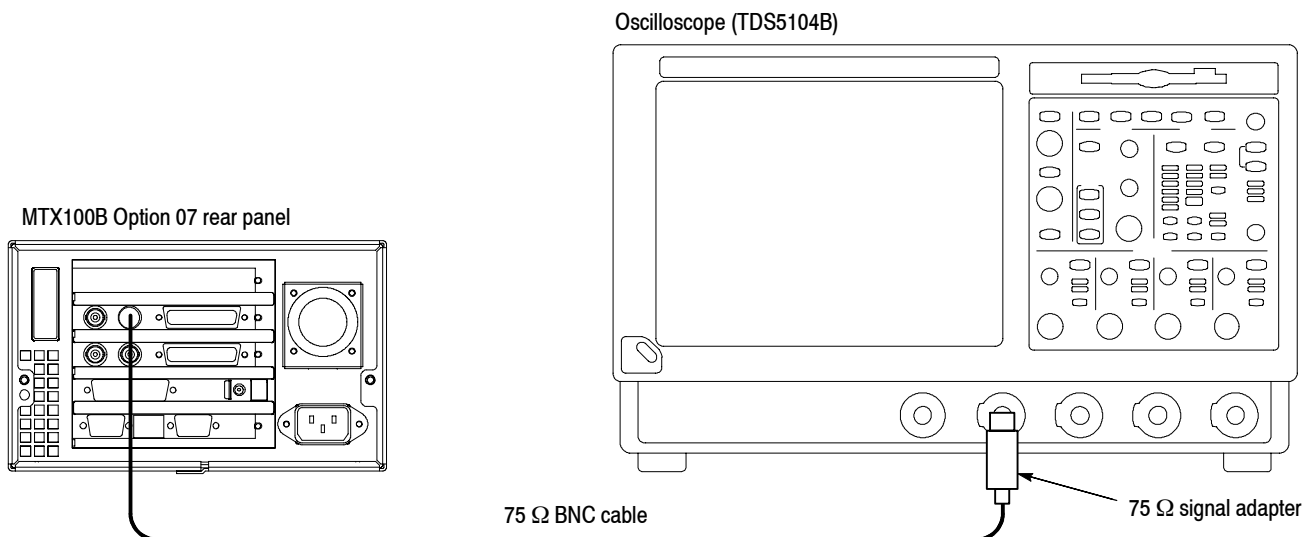

**Figure 3-19: Equipment connection for verifying output signal- SMPTE310M interface**

2. Set the oscilloscope settings as indicated below:

Vertical scale . . . . . 200 mV/div  
Horizontal scale . . . . . 1.25 ns/div  
Trigger position . . . . . 50%  
Acquire mode . . . . . Average 32  
Trigger mode . . . . . AUTO  
Trigger source . . . . . CH1  
Trigger level . . . . . 0 V  
Trigger slope . . . . . Rising Edge  
Input impedance . . . . . 50  $\Omega$   
Measure . . . . . Amplitude, Rise Time, Fall Time  
Ref Level . . . . . High Ref 80%, Low Ref 20%  
Gating . . . . . Cursor Curs1 Pos1: -2.5 ns/Curs2: 2.75 ns

3. Open the **test40.TRP** file on the MTX100B Option 07.
  - a. Select **File > Open** to open the **Select File** dialog box.
  - b. In the dialog box, select the **test40.TRP** file.
4. Press the **Play/Pause** button on the MTX100B Option 07 to start playing the test40.TRP file.
5. Use the oscilloscope to measure that the amplitude, rise and fall times are as follows:

Amplitude: 720 mV to 880 mV  
Rise and fall time:  $\leq 1.2$  ns

#### **Checking the ASI Play Operation.**

6. Disconnect the BNC cable from the 75  $\Omega$  signal adapter on the oscilloscope input, and then connect the cable to the ASI/SMPTE In connector on the MPEG analyzer. See Figure 3-20.

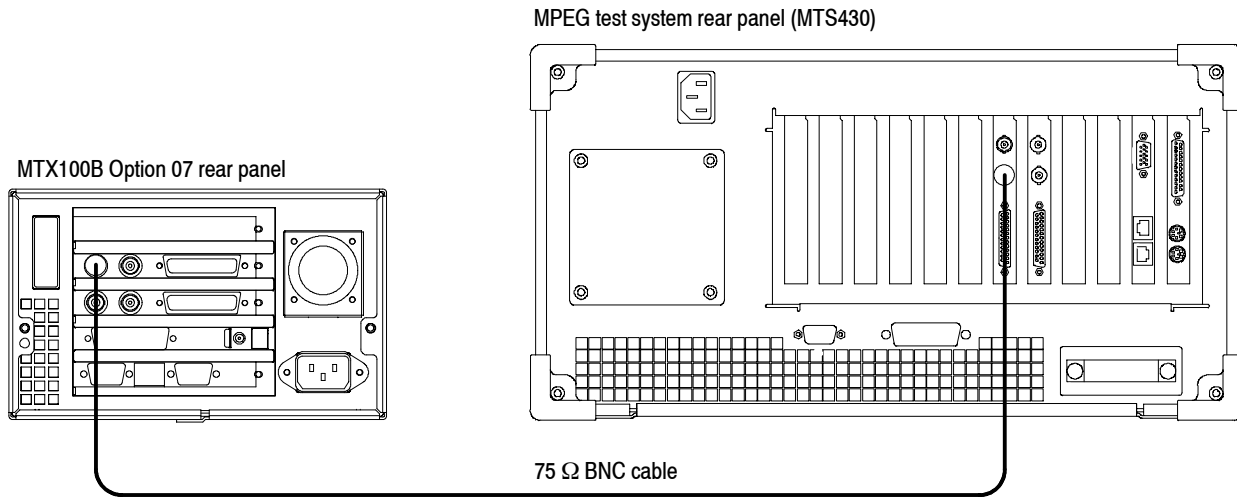

**Figure 3-20: Equipment connection for verifying the ASI play operation**

7. Start the **MPEG Player** application on the MPEG analyzer.
8. Set the application to the **Record** mode.
9. Set the MPEG analyzer settings as indicated below:

**Record menu**

Source ..... SPI/ASI/310M  
Target ..... RAM, Record Size: 100 MB

**SPI/ASI/310M menu**

Input Port ..... BNC  
BNC Port ..... ASI

**File menu**

Save Mode ..... Over write  
Save ..... E:\MTXRTX\_Test streams\Record\_Files\  
ASI214Mbps.trp

10. On the MTX100B Option 07, make the following settings:

**Play menu**

Clock . . . . . Data Rate: 214 Mbps  
Update . . . . . Off  
Source . . . . . RAM

**310M/ASI/SPI menu**

BNC Port . . . . . ASI  
Through Out . . . . . Off

11. Press the **Play/Pause** button on the MTX100B Option 07 to start playing the test40.TRP.
12. Verify that the hierarchic view is displayed on the MPEG analyzer screen. In addition, verify that the bit rate is **214 Mbps** and the packet size is **188** bytes.
13. Click the **Record** button on the MPEG Player application to record the file.
14. After recording is completed, press the **Stop** button on the MTX100B Option 07.
15. Disconnect the 75  $\Omega$  BNC cable from the MTX100B Option 07 and MPEG analyzer.

**Checking the ASI Record Operation.**

16. Use the 75  $\Omega$  BNC cable to connect the SMPTE/ASI Input connector on the MTX100B Option 07 to the ASI/SMPTE Out connector on the MPEG analyzer. See Figure 3-21.

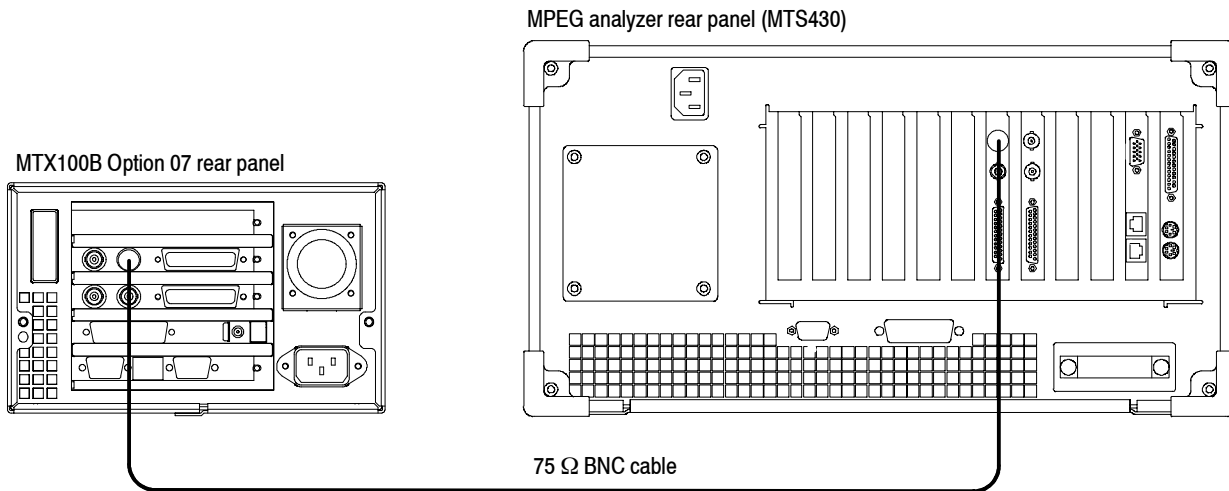

**Figure 3-21: Equipment connection for verifying the ASI record operation**

17. Press the **Record** button on the MTX100B Option 07 to display the Record screen.

18. On the MTX100B Option 07, make the following settings:

**Record menu**

Source . . . . . 310M/ASI/SPI  
 Record size . . . . . 100 MB  
 Target . . . . . RAM

**310M/ASI/SPI menu**

Input Port . . . . . BNC  
 BNC Port . . . . . ASI

**File menu**

Save Mode . . . . . Over Write  
 Save . . . . . D:\Record\_Files\ASI214Mbps.trp

19. Set the MPEG analyzer to the Play mode.

20. Select **File > Open** on the MPEG analyzer to display the Open dialog box.

21. In the dialog box, navigate to the **E:\MTXRTX\_Test Streams\Record\_Files** directory, and then select the **ASI214Mbps.trp** file.



22. Set the following settings on the MPEG analyzer:

**Play menu**

Clock . . . . . Data Rate: 214 Mbps  
Update . . . . . Off  
Source . . . . . RAM

**SPI/ASI/310M menu**

BNC Port . . . . . ASI  
Through Out . . . . . Off

23. Click the **Play** button on the MPEG analyzer to start playing the ASI214Mbps.trp file.
24. Verify that the hierarchic view is displayed on the MTX100B Option 07 screen. In addition, verify that the bit rate is **214 Mbps** and packet size is **188** bytes.
25. Press the **Record** button on the MTX100B Option 07 to record the file.
26. After recording is completed, click the **Stop** button on the MPEG analyzer.
27. Exit the MPEG Player application on the MPEG analyzer.
28. Disconnect the BNC cable from the MTX100B Option 07 and MPEG analyzer.

**Checking the Recorded File.**

29. Use the 75  $\Omega$  BNC cable to connect the SMPTE310M/ASI Output connector on the MTX100B Option 07 to the ASI/SMPTE In connector on the MPEG analyzer. See Figure 3-22.

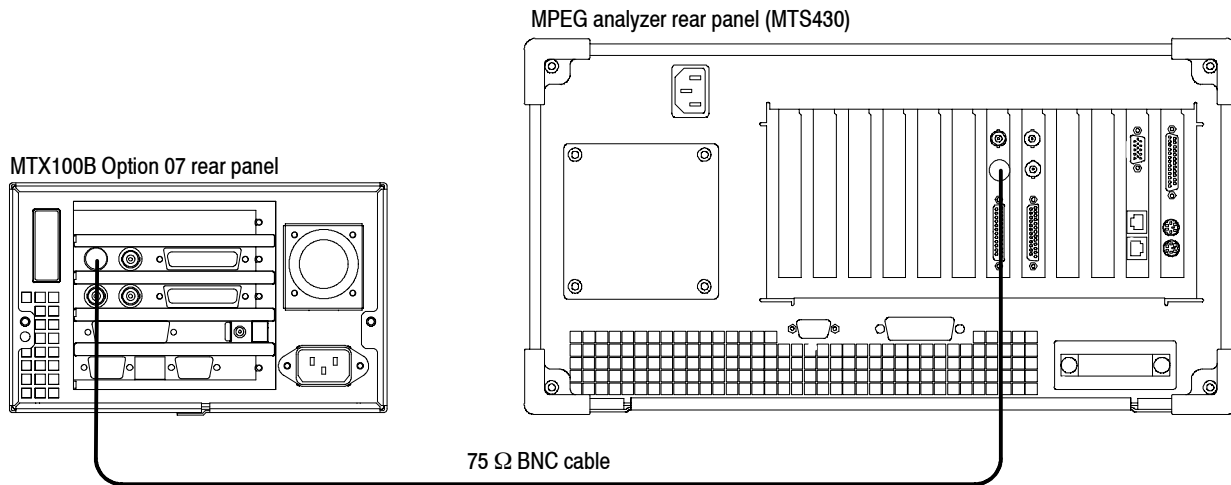

**Figure 3-22: Equipment connection for verifying the recorded file-ASI interface**

30. Press the **Play/Pause** button on the MTX100B Option 07 to display the Play screen.
31. Select **Play > Update > On**.
32. Open the **ASI214Mbps** file on the MTX100B Option 07.
  - a. Select **File > Open** to open the **Select File** dialog box.
  - b. In the dialog box, navigate to the **D:\Record\_Files** directory, and then select the **ASI214Mbps.trp** file.
33. Press the **Play/Pause** button to start playing the file.
34. Start the **TS Compliance Analyzer** on the MPEG analyzer.
35. In the **Open Transport Stream** dialog box, select **Real-time Analysis**, and then make the following settings:
  - Interfaces . . . . . ASI
  - Interface Settings . . . . Time Stamping
36. Verify that the hierarchic view is displayed on the MPEG analyzer screen and that no error messages appear. In addition, verify that the bit rate is **40 Mbps** and that the packet size is **188 bytes**.

---

**NOTE.** Ignore Program 3 and PID 120 (0x78) errors in the hierarchical view because these are caused by the original test40.TRP file.

---

37. Press the **Stop** button on the MTX100B Option 07 to stop the stream output.

38. Disconnect the 75  $\Omega$  BNC cable from the MTX100B Option 07 and MPEG analyzer.

### Checking the SMPTE310M Play Operation.

39. Use the 75  $\Omega$  BNC cable to connect the SMPTE310M/ASI Output connector on the MTX100B Option 07 to the ASI/SMPTE In connector on the MPEG analyzer. See Figure 3-23.

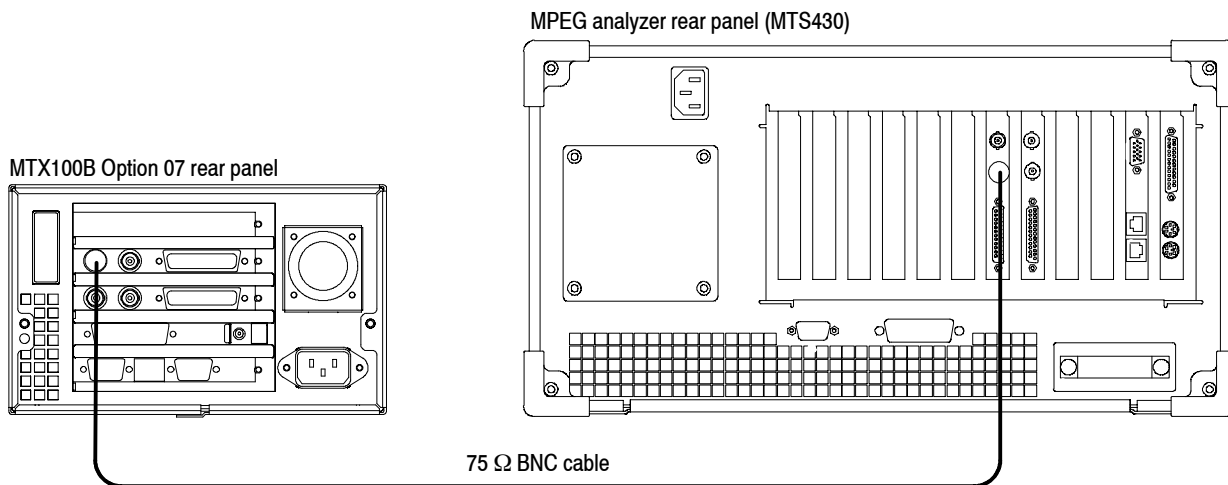

**Figure 3-23: Equipment connection for verifying the SMPTE310M play operation**

40. Start the **MPEG Player** application on the MPEG analyzer.
41. Set the application to the **Record** mode.
42. Set the MPEG analyzer settings as indicated below:

#### **Record menu**

Source . . . . . SPI/ASI/310M  
Target . . . . . RAM, Record Size: 100 MB

#### **SPI/ASI/310M menu**

Input Port . . . . . BNC  
BNC Port . . . . . 310M

#### **File menu**

Save Mode . . . . . Over write  
Save . . . . . E:\MTXRTX\_Test streams\Record\_Files\  
S310M.trp

43. Open the **Flower.trp** file on the MTX100B Option 07.
  - a. Select **File > Open** to open the **Select File** dialog box.
  - b. In the dialog box, navigate to the **D:\525** directory, and then select the **Flower.trp** file.

44. On the MTX100B Option 07, make the following settings:

**Play menu**

Clock . . . . . Data Rate: 19.392658 Mbps  
Update . . . . . Off  
Source . . . . . RAM

**310M/ASI/SPI menu**

BNC Port . . . . . 310M 8VSB  
Through Out . . . . Off

45. Press the **Play/Pause** button on the MTX100B Option 07 to start playing the **Flower.trp** file.
46. Verify that the hierarchic view is displayed on the MPEG analyzer screen. In addition, verify that the bit rate is **19.392 Mbps** and packet size is **188** bytes.
47. Click the **Record** button on the MPEG Player application to record the file.
48. After recording is completed, press the **Stop** button on the MTX100B Option 07.
49. Disconnect the 75  $\Omega$  BNC cable from the MTX100B Option 07 and MPEG analyzer.

**Checking the SMPTE310M Record Operation.**

50. Use the 75  $\Omega$  BNC cable to connect the SMPTE310M/ASI Input connector on the MTX100B Option 07 to the ASI/SMPTE Out connector on the MPEG analyzer. See Figure 3-24.

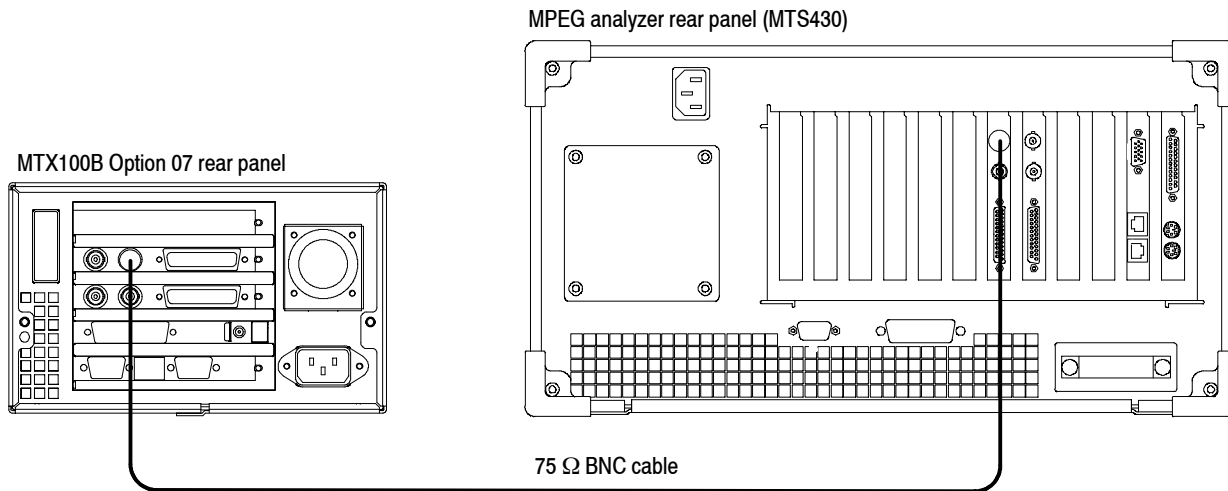

**Figure 3-24: Equipment connection for verifying the SMPTE310M record operation**

51. Press the **Record** button on the MTX100B Option 07 to display the Record screen.
52. On the MTX100B Option 07, make the following settings:
- Record menu**  
Source . . . . . 310M/ASI/SPI  
Record size . . . . . 100 MB  
Target . . . . . RAM
- 310M/ASI/SPI menu**  
Input Port . . . . . BNC  
BNC Port . . . . . 310M
- File menu**  
Save Mode . . . . . Over Write  
Save . . . . . D:\Record\_Files\S310M.trp
53. Set the MPEG analyzer to the Play mode.
54. Select **File > Open** on the MPEG analyzer to display the Open dialog box.
55. In the dialog box, navigate to the **E:\MTXRTX\_Test Streams\Record\_Files** directory, and then select the **S310M.trp** file.

56. On the MPEG player, make the following settings:

**Play menu**

Update . . . . . Off

Source . . . . . RAM

**SPI/ASI/310M menu**

BNC Port . . . . . 310M 8VSB

Through Out . . . . Off

57. Click the **Play** button on the MPEG analyzer to start playing the S310M.trp file.

58. Verify that the hierarchic view is displayed on the MTX100B Option 07 screen. In addition, verify that the bit rate is **19.392 Mbps** and packet size is **188** bytes.

59. Press the **Record** button on the MTX100B Option 07 to record the file.

60. After recording is completed, click the **Stop** button on the MPEG analyzer.

61. Exit the MPEG Player application on the MPEG analyzer.

62. Disconnect the 75 Ω BNC cable from the MTX100B Option 07 and MPEG analyzer.

**Checking the Recorded File.**

63. Use the 75 Ω BNC cable to connect the SMPTE310M/ASI Output connector on the MTX100B Option 07 to the ASI/SMPTE In connector on the MPEG analyzer. See Figure 3-25.

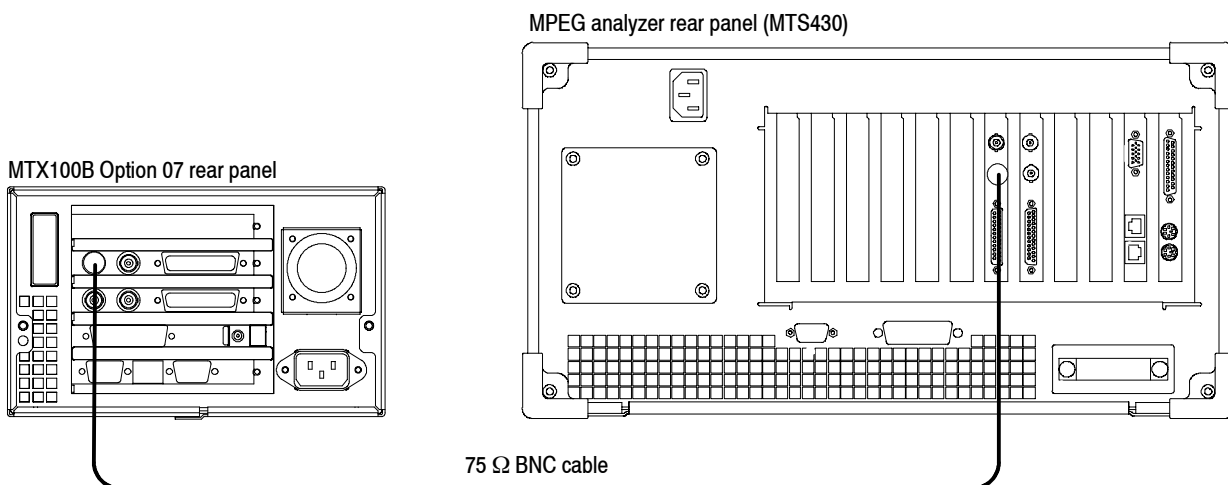

**Figure 3-25: Equipment connection for verifying the recorded file-ASI interface**

64. Press the **Play/Pause** button on the MTX100B Option 07 to display the Play screen.
65. Open the **310M.trp** file on the MTX100B Option 07.
  - a. Select **File > Open** to open the Select File dialog box.
  - b. In the dialog box, navigate to the **D:\Record\_Files** directory, and then select the **310M.trp** file.
66. Select **Play > Update > On**.
67. Press the **Play/Pause** button to start playing the file.
68. Start the **TS Compliance Analyzer** on the MPEG analyzer.
69. In the **Open Transport Stream** dialog box, select **Real-time Analysis**, and then make the following settings:
  - Interfaces . . . . . ASI
  - Interface Settings . . . . Time Stamping
70. Verify that the hierarchic view is displayed on the MPEG analyzer screen and that no error messages appear. In addition, verify that the bit rate is **19.392 Mbps** and that the packet size is **188** bytes.

---

**NOTE.** Ignore 3.4.a Unref PID error in the Priority 3 row.

---

71. Press the **Stop** button on the MTX100B Option 07 to stop the stream output.
72. Disconnect the 75  $\Omega$  BNC cable from the MTX100B Option 07 and MPEG analyzer.

#### **Checking the SPI Record Operation.**

1. Use the parallel interface cable to connect the SPI Input connector on the MTX100B Option 07 to the DVB SPI Out connector on the MPEG analyzer. See Figure 3-26.

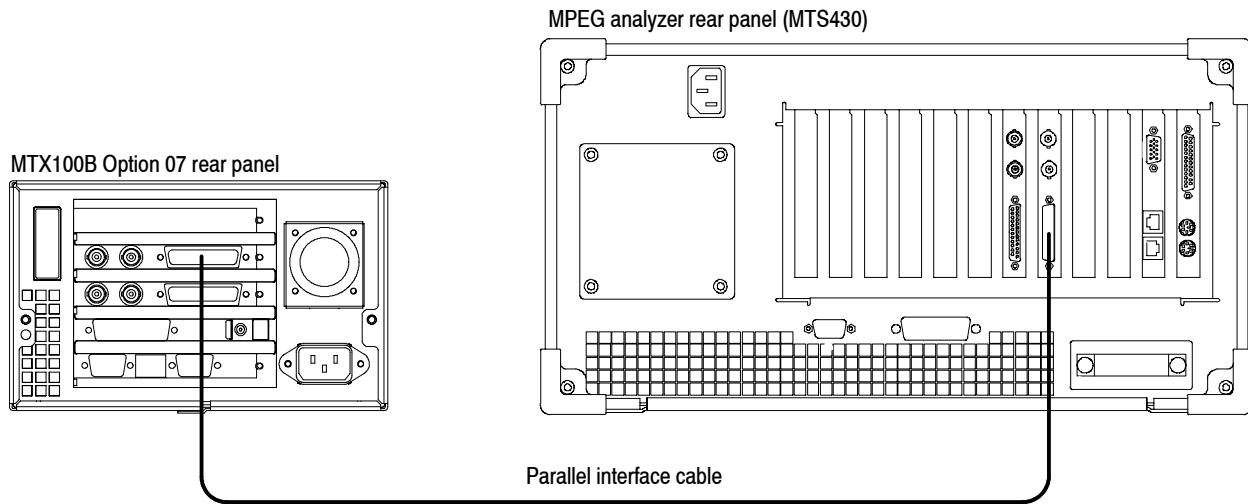

**Figure 3-26: Equipment connection for verifying the SPI record operation**

2. Press the **Record** button on the MTX100B Option 07 to display the Record screen.
3. On the MTX100B Option 07, make the following settings:
  - Record menu**
  - Source . . . . . SPI
  - Target . . . . . RAM
  - Record Size . . 100 MB
  - File menu**
  - Save Mode . . . . . Over Write
  - Save Mode . . . . . D:\Record\_Files\SPI214Mbps
4. Change the MPEG analyzer to Play mode.
5. Select **File > Open** on the MPEG analyzer to display the Open dialog box.
6. In the dialog box, navigate to the **E:\MTXRTX\_Test streams\Record\_Files**, and then select the **SPI214Mbps.trp** file.
7. On the MPEG analyzer, make the following settings:
  - Play menu**
  - Clock . . . . . Data Rate: 214 Mbps
  - Update . . . . . Off
  - Source . . . . . RAM
8. Click the **PLAY** button on the MPEG Analyzer to start playing the **SPI214Mbps.trp** file.



9. Verify that the hierarchic view is displayed on the MTX100B Option 07 screen. In addition, verify that the bit rate display is **214 Mbps** and the packet size display is **188** bytes.
10. Press the **Record** button on the MTX100B Option 07 to record the file.
11. After recording is completed, click the **Stop** button on the MPEG analyzer.
12. Exit the MPEG Player application on the MPEG analyzer.

#### Checking the Recorded File.

13. Change the interface cable connection from DVB/SPI Out connector to DVB/SPI In connector on the MPEG analyzer.
14. Start the **TS Compliance Analyzer** on the MPEG analyzer.
15. In the **Open Transport Stream** dialog box, select **Real-time Analysis**, and then make the following settings:
  - Interfaces . . . . . ASI
  - Interface Settings . . . . Time Stamping
16. Press the **Play/Pause** button on the MTX100B Option 07 to display the Play screen.
17. Select **File > Open** to open the **Select File** dialog box.
18. In the dialog box, navigate to the **D:\ Record\_Files** directory, and then select the **SPI214Mbps.trp** file.
19. Select **Play > Update > On**.
20. Press the **Play/Pause** button on the MTX100B Option 07 to start playing the SPI214Mbps.trp file.
21. Verify that the hierarchic view is displayed on the MPEG analyzer screen and that no error messages appear. In addition, verify that the bit rate is **40 Mbps** and that the transport stream packet size is **188** bytes.

---

**NOTE.** Ignore Program 3 and PID 120 (0x78) errors in the hierarchical view because these are caused by the original test40.TRP file.

---

22. Press the **Stop** button on the MTX100B Option 07.
23. Close the TS Compliance Analyzer window.

This completes the MTX100B performance verification.





# Maintenance



# Maintenance

This section contains the information needed to do periodic and corrective maintenance on the MTX100B. The following subsections are included:

- *Preparation*
- *Inspection and Cleaning*
- *Removal and Installation Procedures*
- *Verifying the BIOS Configuration*
- *Troubleshooting*
- *System Software Recovery*
- *Using the Rescue Disc*

## Related Maintenance Procedures

The following sections contain information and procedures related to maintenance.

- Section 2, *Theory of Operation*, contains a circuit description at the module or block level.
- Section 3, *Performance Verification*, contains procedures that may be useful in isolating problems to modules by testing the MTX100B performance.
- Section 6, *Diagrams*, contains a block diagram using individual modules as blocks and an interconnection diagram showing connections between the modules.
- Section 7, *Replaceable Parts List*, lists all field replaceable modules by part number.

## Preparation

Before servicing this product, read the *General Safety Summary, Safety Summary, and Introduction* at the front of the manual, and the following ESD information.



---

**CAUTION.** *Static discharge can damage any semiconductor component in the MTX100B.*

---

### Preventing ESD

When performing any service that requires internal access to the MTX100B, adhere to the following precautions to avoid damaging internal modules and their components due to electrostatic discharge (ESD).

1. Minimize handling of static-sensitive modules.
2. Transport and store static-sensitive modules in their static protected containers or on a metal rail. Label any package that contains static-sensitive modules.
3. Discharge the static voltage from your body by wearing a grounded antistatic wrist strap while handling these modules. Perform service of static-sensitive modules only at a static-free work station.
4. Nothing capable of generating or holding a static charge should be allowed on the work station surface.
5. Handle circuit boards by the edges when possible.
6. Do not slide the modules over any surface.
7. Avoid handling modules in areas that have a floor or work-surface covering capable of generating a static charge.

## Inspection and Cleaning

*Inspection and Cleaning* describes how to inspect for dirt and damage. It also describes how to clean the exterior and interior of the MTX100B. Inspection and cleaning are done as preventive maintenance. Preventive maintenance, when done regularly, may prevent the MTX100B from malfunctioning and enhance its reliability.

Preventive maintenance consists of visually inspecting and cleaning the MTX100B and using general care when operating it.

How often preventative maintenance should be performed depends on the severity of the environment in which the MTX100B is used.

### General Care

The cabinet helps keep dust out of the MTX100B, and is needed to meet EMI and cooling requirements. The cabinet should be in place when operating the MTX100B. The front cover protects the front panel and display from dust and damage. Install the front cover when storing or transporting the MTX100B.

### Inspection and Cleaning Procedures

Inspect and clean the MTX100B as often as operating conditions require. The collection of dirt on components inside can cause them to overheat and break-down. (Dirt acts like an insulating blanket, preventing efficient heat dissipation.) Dirt also provides an electrical conduction path that could cause an MTX100B failure, especially under high-humidity conditions.



---

**CAUTION.** *Avoid the use of chemical cleaning agents that might damage the plastics used in this MTX100B. Use only deionized water when cleaning the menu buttons or front-panel buttons. Use an ethyl alcohol solution as a cleaner and rinse with deionized water.*

---

**Inspection — Exterior.** Inspect the outside of the MTX100B for damage, wear, and missing parts, using Table 4-1 as a guide. An MTX100B that appears to have been dropped or otherwise abused should be checked thoroughly to verify correct operation and performance. Immediately repair defects that could cause personal injury or lead to further damage to the MTX100B.

**Table 4-1: External inspection check list**

Item	Inspect for	Repair action
Cabinet, front panel, and cover	Cracks, scratches, deformations, damaged hardware or gaskets.	Repair or replace defective module.
Front-panel buttons	Missing, damaged, or loose buttons.	Repair or replace missing or defective buttons.
Connectors	Broken shells, cracked insulation, and deformed contacts. Dirt in connectors.	Repair or replace defective modules. Clear or wash out dirt.
Accessories	Missing items or parts of items, bent pins, broken or frayed cables, and damaged connectors.	Repair or replace damaged or missing items, frayed cables, and defective modules.

**Cleaning Procedure — Exterior.** To clean the MTX100B exterior, perform the following steps:

1. Remove loose dust on the outside of the MTX100B with a lint free cloth.
2. Remove remaining dirt with a lint free cloth dampened in a general purpose detergent-and-water solution. Do not use abrasive cleaners.
3. Clean the light filter protecting the monitor screen with a lint-free cloth dampened with a gentle, general purpose detergent-and-water solution.



---

**CAUTION.** *To prevent getting moisture inside the MTX100B during external cleaning, use only enough liquid to dampen the cloth or applicator.*

---



**Inspection — Interior.** To access the inside of the MTX100B for inspection and cleaning, refer to the *Removal and Installation Procedures* in this section.

Inspect the internal portions of the MTX100B before damage and wear, using Table 4-2 as a guide. Defects found should be repaired immediately.



**CAUTION.** To prevent damage from electrical arcing, ensure that circuit boards and components are dry before applying power to the MTX100B.

**Table 4-2: Internal inspection check list**

Item	Inspect for	Repair action
Circuit boards	Loose, broken, or corroded solder connections. Burned circuit boards. Burned, broken, or cracked circuit-run plating.	Remove failed module and replace with a fresh module.
Resistors	Burned, cracked, broken, blistered condition.	Remove failed module and replace with a fresh module.
Solder connections	Cold solder or rosin joints.	Resolder joint and clean with isopropyl alcohol.
Capacitors	Damaged or leaking cases. Corroded solder on leads or terminals.	Remove damaged module and replace with a fresh module from the factory.
Semiconductors	Loosely inserted in sockets. Distorted pins.	Firmly seat loose semiconductors. Remove devices that have distorted pins. Carefully straighten pins (as required to fit the socket), using long-nose pliers, and reinsert firmly. Ensure that straightening action does not crack pins, causing them to break off.
Wiring and cables	Loose plugs or connectors. Burned, broken, or frayed wiring.	Firmly seat connectors. Repair or replace modules with defective wires or cables.
Chassis	Dents, deformations, and damaged hardware.	Straighten, repair, or replace defective hardware.

**Cleaning Procedure — Interior.** To clean the MTX100B interior, perform the following steps:

1. Blow off dust with dry, low-pressure, deionized air (approximately 9 psi).
2. Remove any remaining dust with a lint-free cloth dampened in ethyl alcohol and rinse with warm deionized water. (A cotton-tipped applicator is useful for cleaning in narrow spaces and on circuit boards.)

---

**STOP.** *If, after performing steps 1 and 2, a module is clean upon inspection, skip the remaining steps.*

---

3. If steps 1 and 2 do not remove all the dust or dirt, the MTX100B may be spray washed using a solution of ethyl alcohol by performing steps 4 through 8.
4. Gain access to the parts to be cleaned by removing easily accessible shields and panels (see *Removal and Installation Procedures*).
5. Spray wash dirty parts with the ethyl alcohol and wait 60 seconds for the majority of the alcohol to evaporate.
6. Use hot (120 °F to 140 °F) deionized water to thoroughly rinse them.
7. Dry all parts with low-pressure, deionized air.
8. Dry all components and assemblies in an oven or drying compartment using low-temperature (125 °F to 150 °F) circulating air.

**Lubrication.** There is no periodic lubrication required for the MTX100B.

# Removal and Installation Procedures

This section contains procedures for removal and installation of all mechanical and electrical modules.

## Preparation



---

**WARNING.** *Before performing this or any other procedure in this manual, read the Safety Summary found at the beginning of this manual. Also, to prevent possible damage to components of the MTX100B, read Preventing ESD in this section.*

---

This subsection contains the following items:

- Preparatory information that you need to properly perform the procedures that follow.
- List of tools required to remove and disassemble all modules.
- Three module locator diagrams for finding the External modules (see Figure 4-2 on page 4-11), Board modules (see Figure 4-3 on page 4-12), and Internal modules (see Figure 4-4 on page 4-13) .
- Procedures for removal and reinstallation of the electrical and mechanical modules.
- A disassembly procedure for removal of all the major modules from the MTX100B at one time and for reassembly of those modules into the MTX100B. Such a complete disassembly is normally only done when completely cleaning the MTX100B. (Instructions for cleaning are found under *Inspection and Cleaning* at the beginning of this section.)



---

**WARNING.** *Before performing any procedure in this subsection, disconnect the power cord from the line voltage source. Failure to do so could cause serious injury or death.*

---

**General Instructions**

Read these general instructions before removing a module.

First read over the *Summary of Procedures* that follows to understand how the procedures are grouped. Then read *Equipment Required* for a list of the tools needed to remove and install modules in the MTX100B.

If you are removing a module for service, begin by performing the procedure *Access Procedure* (page 4-14). By following the instructions in that procedure, you remove the module to be serviced while removing the minimum number of additional modules.

**Summary of Procedures**

The procedures are described in the order in which they appear in this section. In addition, you can look up any procedure for removal and reinstallation of any module in the *Table of Contents* of this manual.

- The *Access Procedure* on page 4-14 first directs you to the procedure(s) (if any) that are required to access the module to be serviced, then it directs you to the procedure to remove that module.

**Table 4-3: Summary of procedures**

Procedure	Module	Page
Procedures for External Modules	<ul style="list-style-type: none"> <li>■ Cabinet</li> <li>■ Right-side cover</li> <li>■ Left-side cover</li> <li>■ Front-panel unit</li> <li>■ Front-panel assembly</li> </ul>	4-15
Procedures for Board Modules	<ul style="list-style-type: none"> <li>■ A12 Main board</li> <li>■ CPU board</li> <li>■ A20 PCI Backplane board</li> <li>■ Interface board (Optional)</li> <li>■ Printer connector</li> </ul>	4-21
Procedures for Internal Module	<ul style="list-style-type: none"> <li>■ Hard disk drive</li> <li>■ Internal and external fans</li> <li>■ 12 V main power supply</li> <li>■ A40 AC Distributor board</li> <li>■ RFI filter</li> </ul>	4-26

**Required Equipment.** Most modules in this MTX100B can be removed with a screwdriver handle mounted with a size T-10 Torx screwdriver tip. *Use this tool whenever a procedure step instructs you to remove or install a screw unless a different size screwdriver is specified in that step.* All equipment required to remove and reinstall each module is listed in the first step of its procedure.

**Table 4-4: Tools required for module removal**

Item No.	Name	Description
1	Screwdriver handle	Accepts Torx®-driver bits
2	T-10 Torx® tip	Torx®-driver bit for T-10 size screw heads
3	T-15 Torx® tip	Torx®-driver bit for T-15 size screw heads
4	Nut driver, 1/4 inch	Standard tool

**MTX100B Orientation**

In this manual, procedures refer to “front,” “rear,” and “top” of the MTX100B. Figure 4-1 shows how the sides are referenced. Figures 4-2 through 4-4 show the modules that make up the MTX100B.

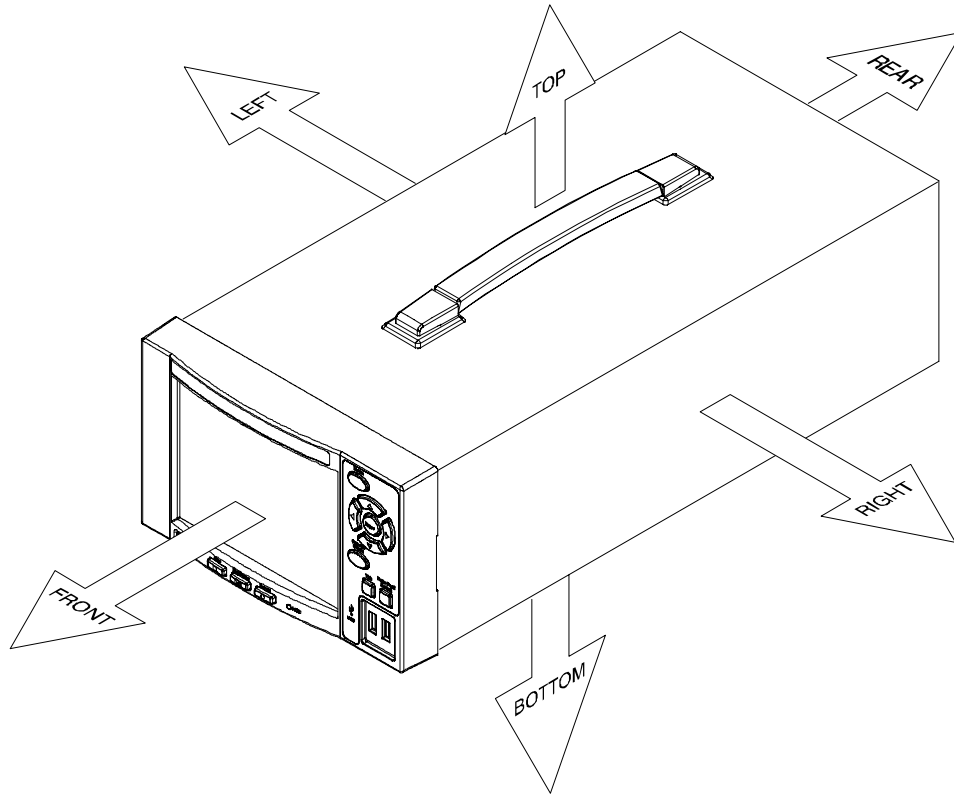

**Figure 4-1: MTX100B orientation**

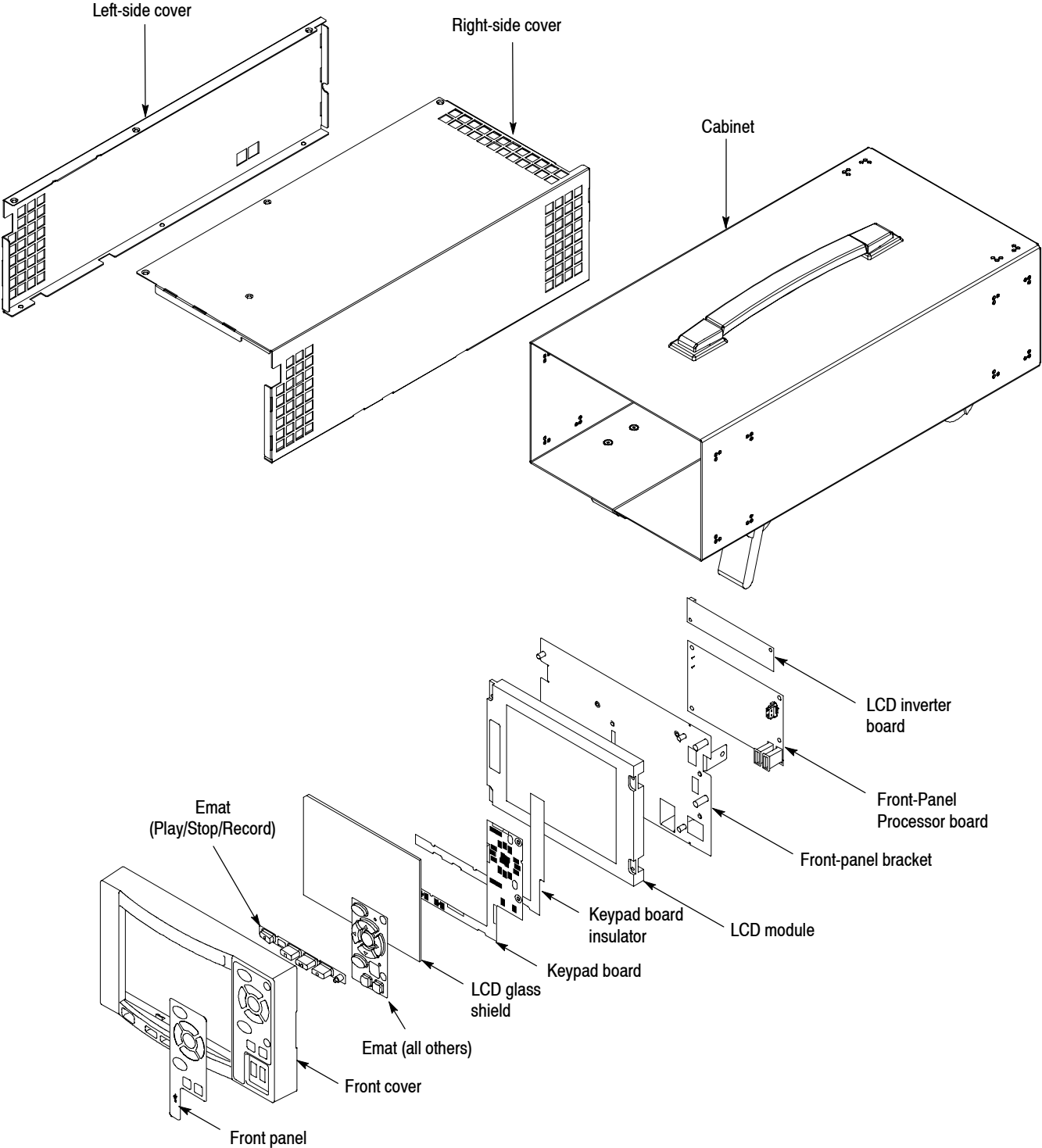
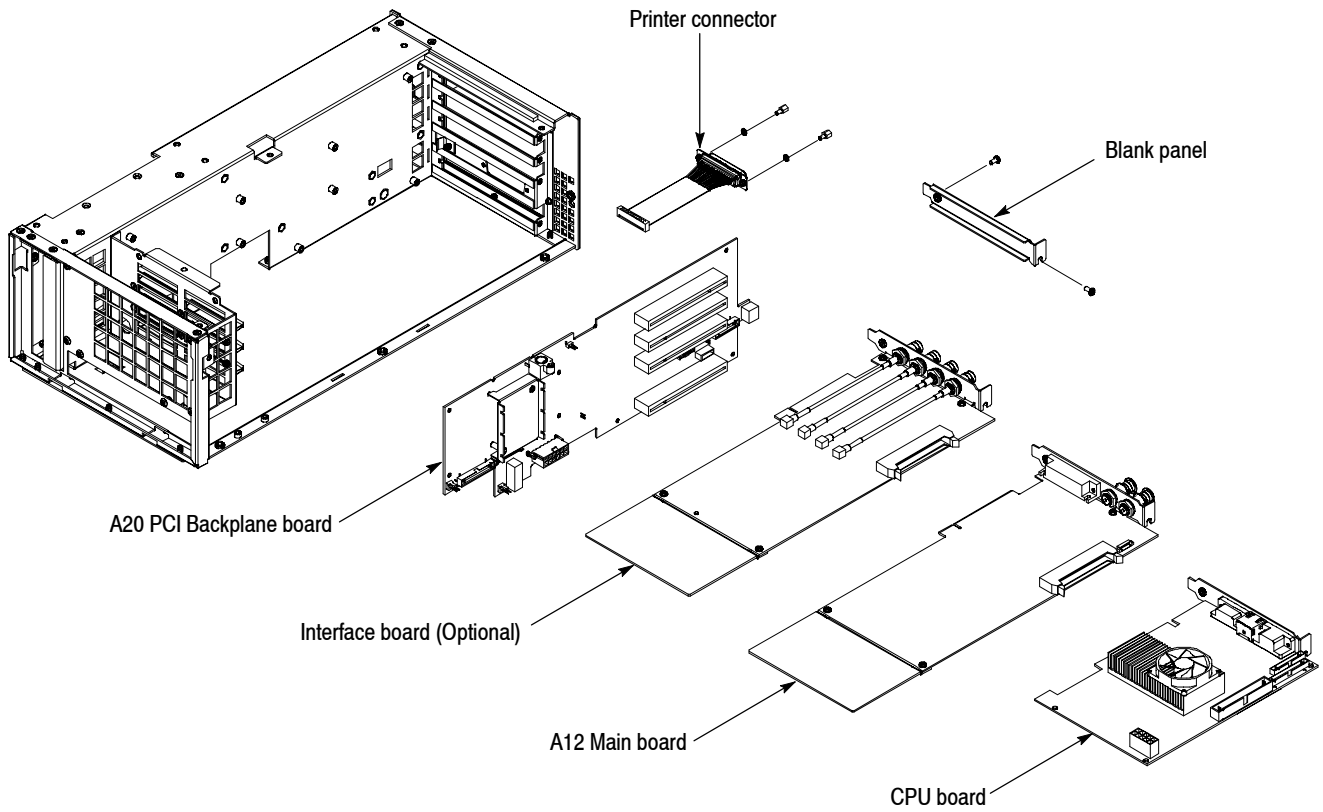

Figure 4-2: External modules



**Figure 4-3: Board modules**



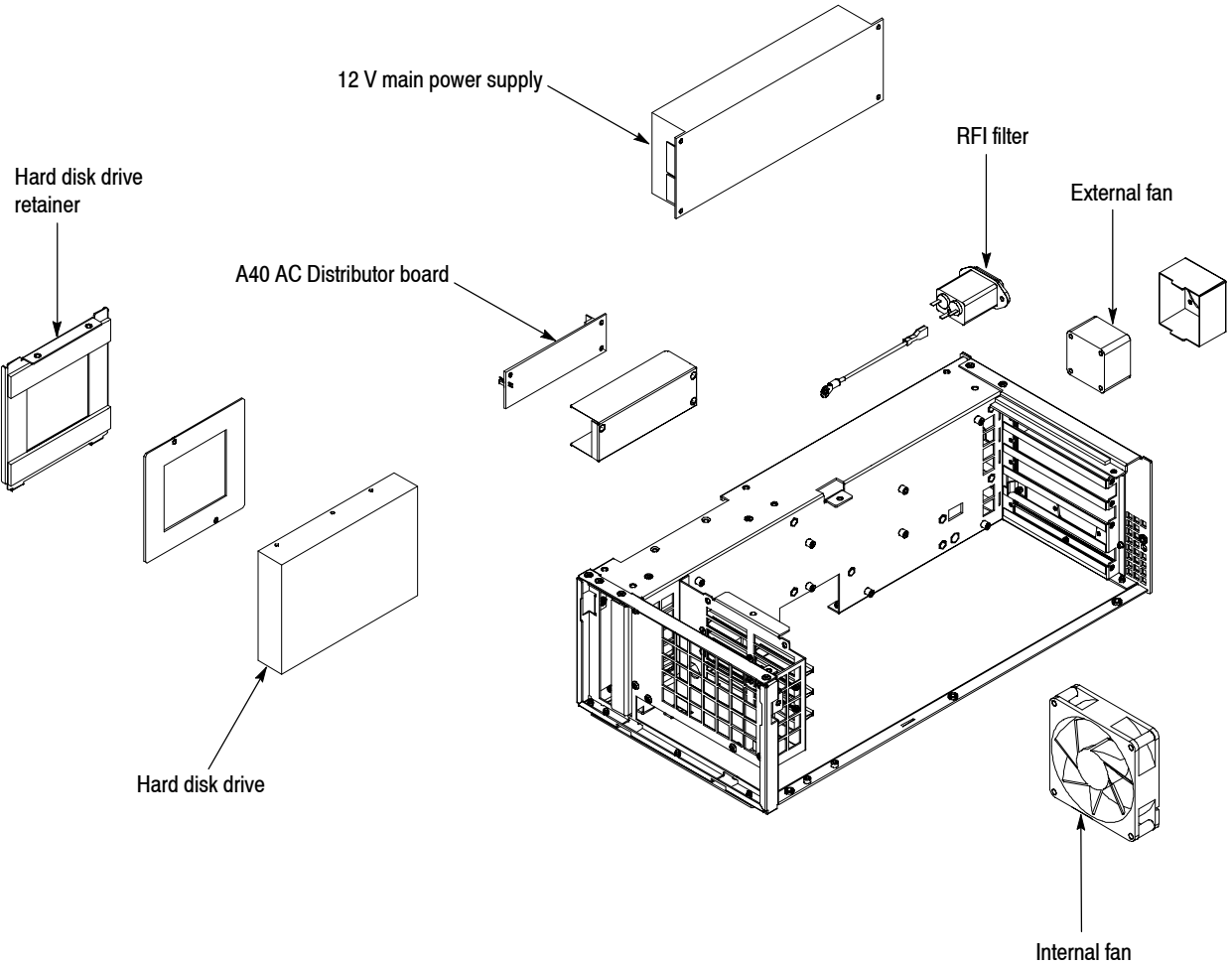

Figure 4-4: Internal modules

## Access Procedure

When you have identified the module to be removed for service, read *General Instructions* found on page 4-8. Then use the flowchart in Figure 4-5 to determine which procedures to use for removing the module. The removal procedures end with installation instructions.

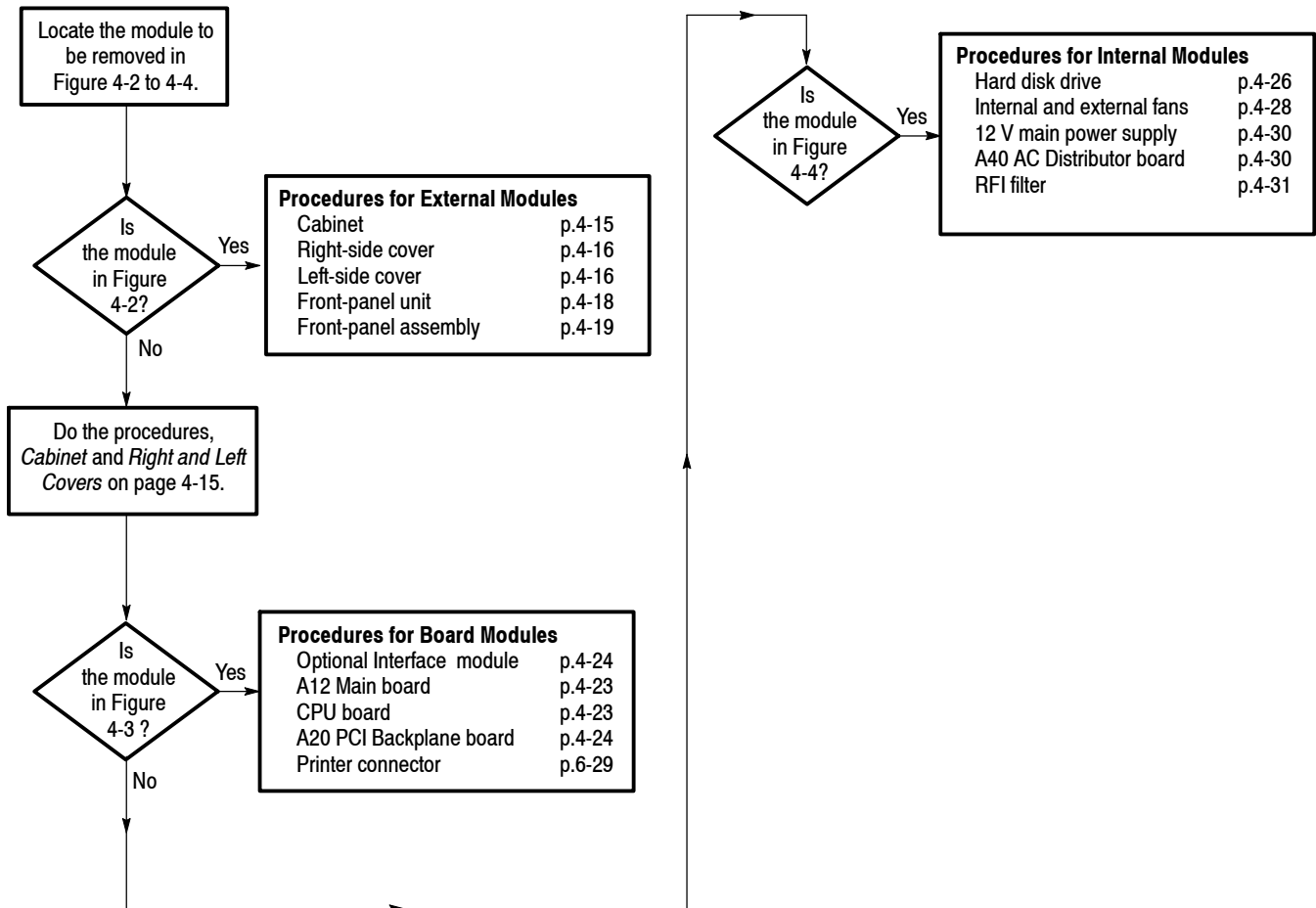

Figure 4-5: Guide to removal procedures

## Procedures for External Modules

Perform the *Access Procedure* (page 4-14) before performing any procedure in this group. This group contains the following procedures:

- *Cabinet*
- Right-side cover
- Left-side cover
- *Front-panel unit*
- *Front-panel assembly*

- Cabinet**
1. *Assemble equipment and locate module to be removed:*
    - a. You need a screwdriver with a T-15 Torx tip.
    - b. Locate the cabinet in the locator diagram *External modules*, Figure 4-2, page 4-11.
  2. *Orient the instrument:* Set the MTX100B so its bottom is down on the work surface and its rear is facing you.
  3. Use a screwdriver with a T-15 Torx tip to remove the two screws securing the cabinet to the MTX100B. See Figure 4-6 on page 4-16.
  4. Grasp the right and left edges of the cabinet toward the back. Push the chassis rear panel, toward the front of the MTX100B, to separate it from the cabinet.
  5. Slide the cabinet off the MTX100B.
  6. *Reinstallation:* Perform steps 3 through 5 in reverse order to reinstall the cabinet.

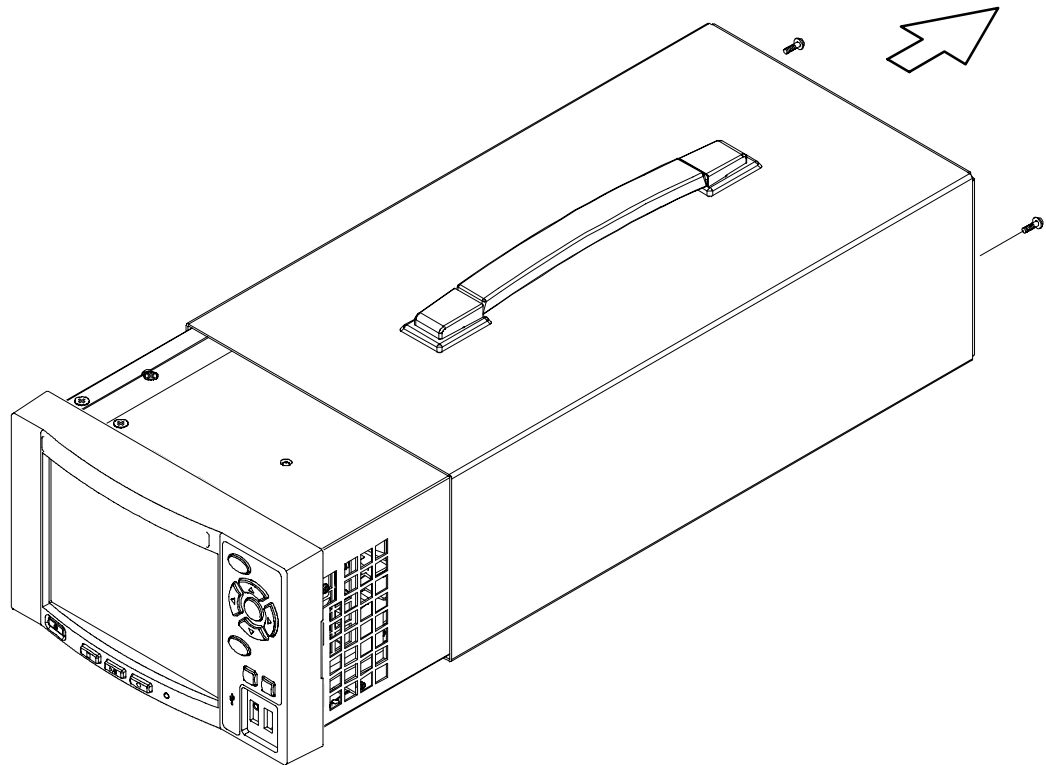

**Figure 4-6: Cabinet removal**

**Right-Side Cover**

1. *Assemble equipment and locate module to be removed:*
  - a. You need a screwdriver with a T-10 Torx tip.
  - b. Locate the right-side cover in the locator diagram *External modules*, Figure 4-2, page 4-11.
2. *Orient the instrument:* Set the MTX100B so its left side is down on the work surface and its front is facing you.
3. Use a screwdriver with a T-10 Torx tip to remove the seven screws securing the right-side cover to the top and bottom of the chassis. See Figure 4-7.
4. Remove the right-side cover from the chassis.
5. *Reinstallation:* Perform steps 3 and 4 in reverse order to reinstall the right-side cover.

**Left-Side Cover**

1. *Assemble equipment and locate module to be removed:*
  - a. You need a screwdriver with a T-10 Torx tip.



**Front-Panel Unit**

1. *Assemble equipment and locate module to be removed:*
  - a. You need a screwdriver with a T-10 Torx tip.
  - b. Locate the front-panel unit in the locator diagram *External modules*, Figure 4-2, page 4-11.
2. *Orient instrument:* Set the MTX100B so its bottom is down on the work surface and its front is facing you.
3. *Remove front-panel unit:* See Figure 4-8.
  - a. Use a screwdriver with a T-10 Torx tip to remove the four screws securing the front-panel unit to the chassis.
  - b. Grasp the front-panel unit and pull it forward.
  - c. Disconnect the cable from J100 on the Front-Panel Processor board.
  - d. Disconnect the cable from J105 on the Front-Panel Processor board.
4. *Reinstallation:* Perform step 3 in reverse order to reinstall the front-panel unit.

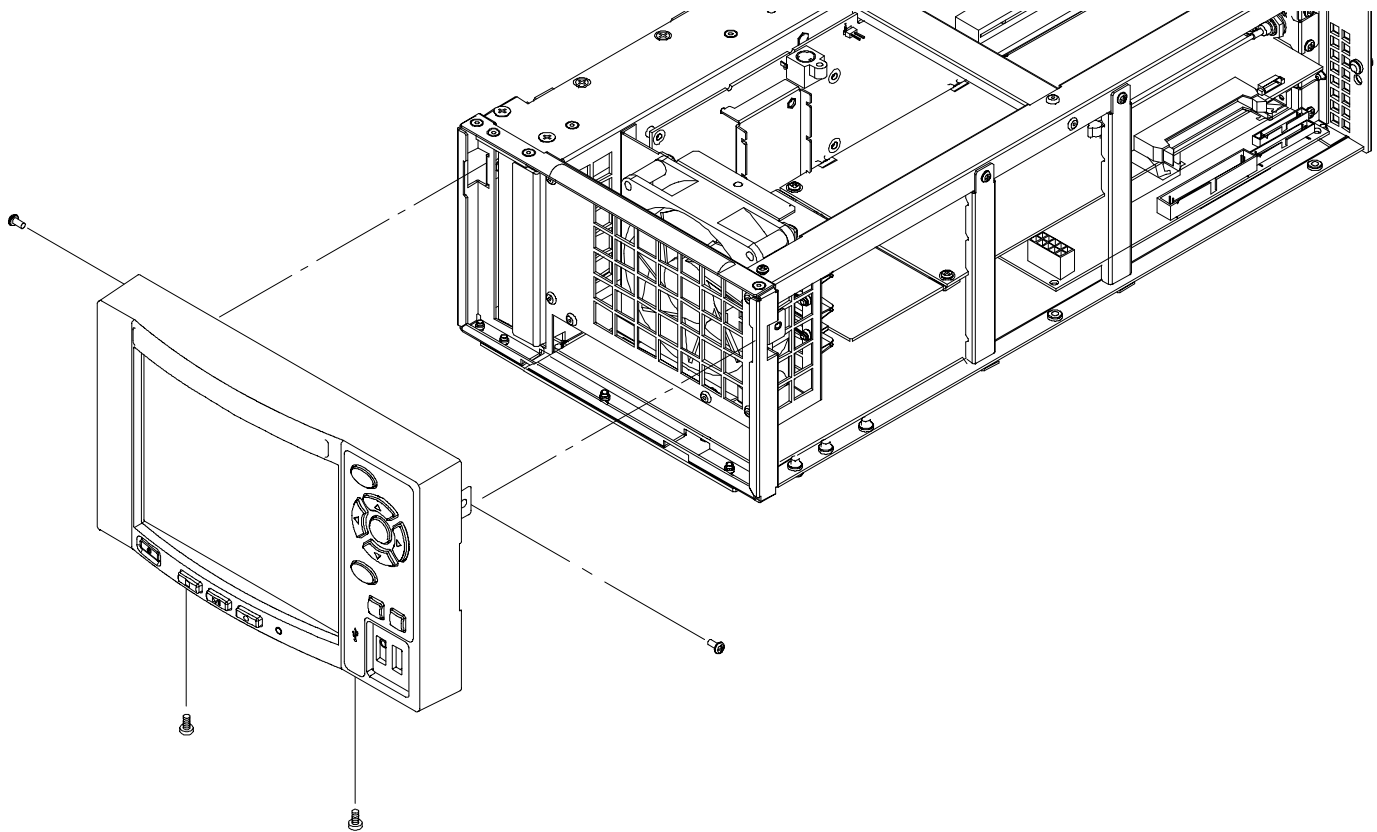

**Figure 4-8: Front-panel unit removal**

**Front-Panel Assembly**

1. *Assemble equipment and locate modules to be removed:*
  - a. You need a screwdriver with a T-10 Torx tip.
  - b. Locate the front-panel assembly in the locator diagram *External modules*, Figure 4-2, page 4-11.
2. *Remove the front cover:* See Figure 4-9 on page 4-20.
  - a. Press the two latches at the bottom of the front cover to release it from the front cover bracket.
  - b. Pull the front cover forward, away from the front-panel bracket.
3. *Remove the Front-Panel Processor board:* See Figure 4-9 on page 4-20.
  - a. Disconnect the cables from J11, J301, and J321 on the Front-Panel Processor board.
  - b. Use a screwdriver with with a T-10 Torx tip to remove the four screws securing the Front-Panel Processor board to the front-panel bracket.
  - c. Lift the board away.
4. *Remove the Keypad board:* See Figure 4-9 on page 4-20.
  - a. Use a screwdriver with a T-10 Torx tip to remove the two screws securing the Keypad board to the front-panel bracket.
  - b. Lift the board away.
5. *Remove the LCD module:* See Figure 4-9 on page 4-20.
  - a. Use a screwdriver with with a T-10 Torx tip to remove the four screws securing the LCD module to the front-panel bracket.
  - b. Lift the LCD module away.
6. Now manually disassemble the front-panel assembly components using Figure 4-9 as a guide. Reverse the procedure to reassemble.
7. *Reinstallation:* Perform steps 2 through 6 in reverse order to reinstall the front-panel assembly.

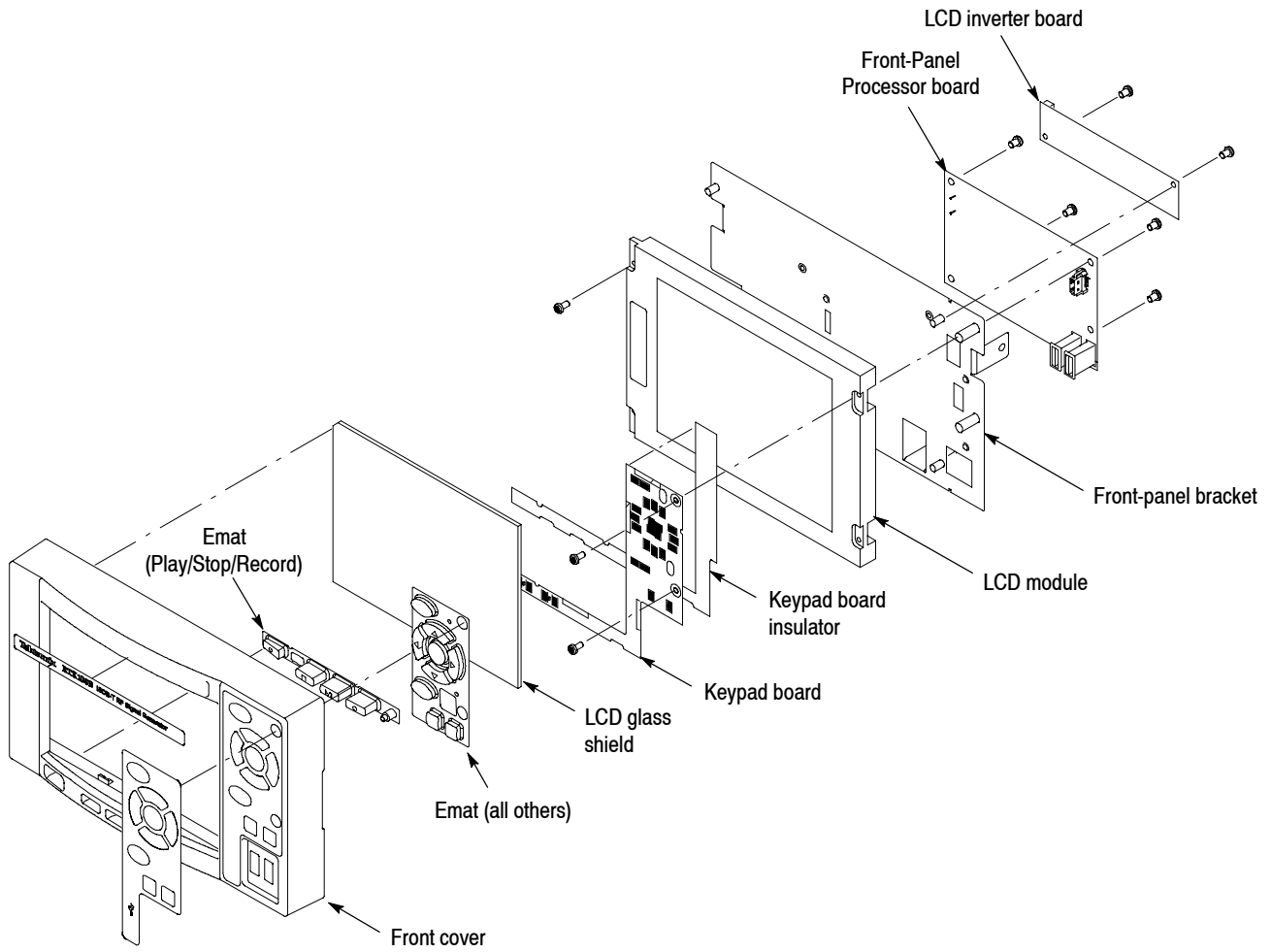

**Figure 4-9: Disassembly of front-panel assembly**



## Procedure for Board Modules

Perform the *Access Procedure* (on page 4-14) before doing any procedure in this group. The procedures are:

- *Top frame and board retainers*
- *Optional interface module (if installed)*
- *A12 Main board*
- *CPU board*
- *A20 PCI Backplane board*
- *Printer connector*

### Top Frame and Board Retainers

1. *Assemble equipment and locate modules to be removed:*
  - You need a screwdriver with a T-10 Torx tip.
2. *Orient the instrument:* Set the MTX100B so its bottom is down on the work surface and its right side is facing you.
3. *Remove the board retainers:* See Figure 4-10 on page 4-22.
  - a. Use a screwdriver a T-10 Torx tip to remove the two screws securing the board retainers to the chassis.
  - b. Lift the retainers away from the chassis.
4. *Remove the top frame:* See Figure 4-10 on page 4-22.
  - a. Use a screwdriver with a T-10 Torx tip to remove the three screws securing the top frame to the chassis.
  - b. Lift the top frame away from the chassis.

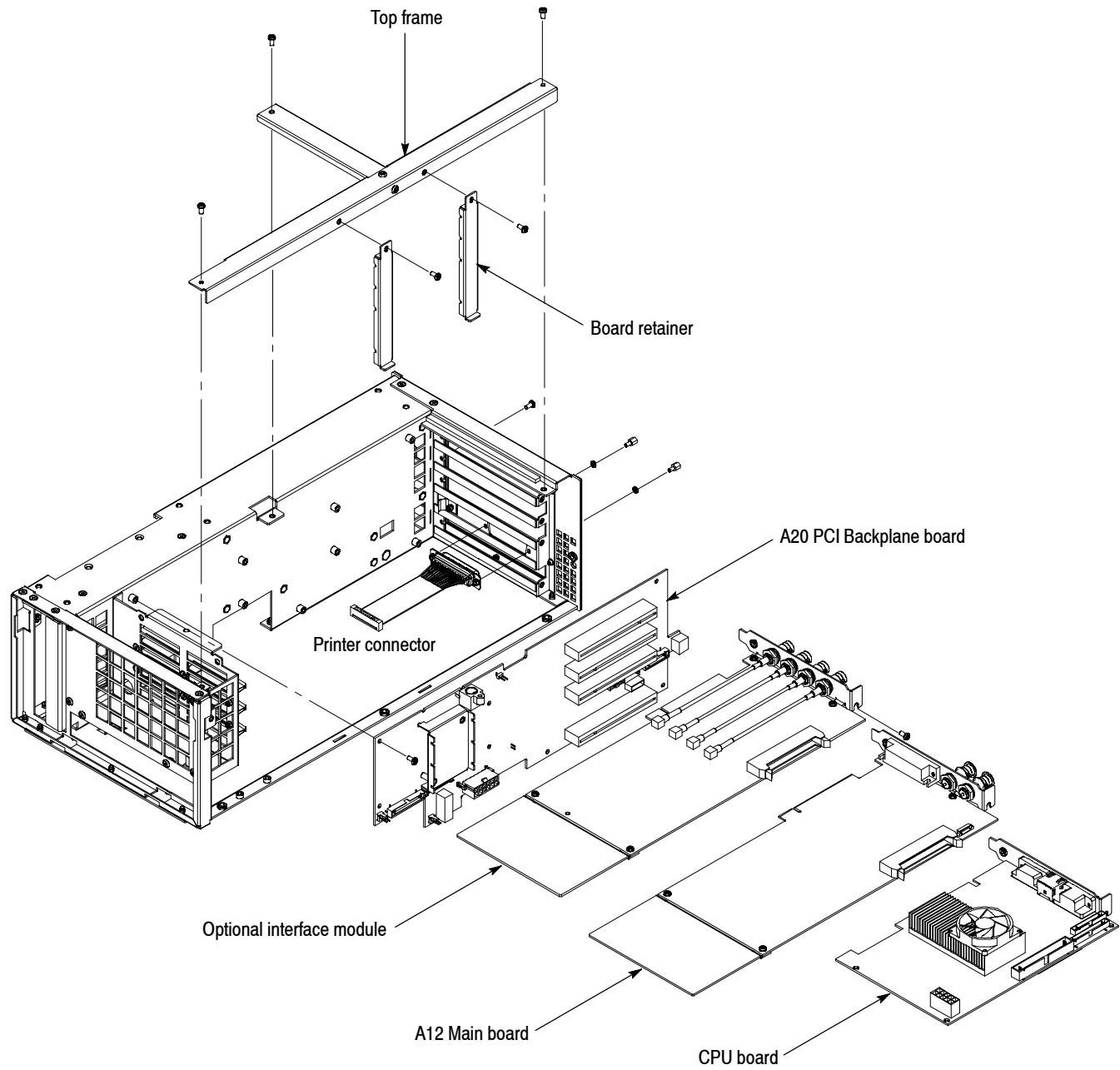

**Figure 4-10: Interface module, A12 Main board, CPU board, and A20 PCI Backplane board removal**

**Optional Interface Module**

1. *Assemble equipment and locate module to be removed:*
  - a. You need a screwdriver with a T-10 Torx tip.
  - b. Locate the interface module in the locator diagram *Board modules*, Figure 4-3, page 4-12.
2. *Orient the instrument:* Set the MTX100B so its bottom is down on the work surface and its right side is facing you.
3. *Remove the interface module:* See Figure 4-10 on page 4-22.
  - a. Disconnect the cable from the A12 Main board.
  - b. Use a screwdriver with a T-10 Torx tip to remove the two screws securing the board bracket to the chassis. See Figure 4-10 on page 4-22.
  - c. Grasp the board and slide it out.
4. *Reinstallation:* Perform step 3 in reverse order to reinstall the interface module.

---

**NOTE.** *If you replace the A12 Main board, you must return the instrument to your local Tektronix Service Center to have instrument-specific information installed on the new board.*

---

**A12 Main Board**

1. *Assemble equipment and locate module to be removed:*
  - a. You need a screwdriver with a T-10 Torx tip.
  - b. Locate the A12 Main board in the locator diagram *Board modules*, Figure 4-3, page 4-12.
2. *Orient the instrument:* Set the MTX100B so its bottom is down on the work surface and its right side is facing you.
3. *Remove the A12 Main board:* See Figure 4-10 on page 4-22.
  - a. If an optional interface module is installed, disconnect the cable from the interface module.
  - b. Use a screwdriver with a T-10 Torx tip to remove the two screws securing the board bracket to the chassis. See Figure 4-10 on page 4-22.
  - c. Grasp the board and slide it out.
4. *Reinstallation:* Perform step 3 in reverse order to reinstall the A12 Main board.

### **CPU Board**

1. *Assemble equipment and locate module to be removed:*
  - a. You need a screwdriver with a T-10 Torx tip.
  - b. Locate the CPU board in the locator diagram *Board modules*, Figure 4-3, page 4-12.
2. *Orient the instrument:* Set the MTX100B so its bottom is down on the work surface and its right side is facing you.
3. *Remove the CPU board:* See Figure 4-10 on page 4-22.
  - a. Disconnect these cables:
    - The cable from the hard disk drive at CN1.
    - The cable from the Printer connector at CN3.
    - The cable from the A20 PCI Backplane board at CN5, CN6, CN9, and CN14.
    - The cable from the Front-Panel Processor board at CN7.
  - b. Use a screwdriver with a T-10 Torx tip to remove the two screws securing the board bracket to the chassis. See Figure 4-10.
  - c. Grasp the board and slide it out.
4. *Reinstallation:* Perform step 3 in reverse order to reinstall the CPU board.

---

**NOTE.** *If you replace the A20 PCI Backplane board, you must return the instrument to your local Tektronix Service Center to have instrument-specific information installed on the new board.*

---

### **A20 PCI Backplane Board**

1. *Assemble equipment and locate module to be removed:*
  - a. You need a screwdriver with a T-10 Torx tip.
  - b. Locate the A20 PCI Backplane board in the locator diagram *Board modules*, Figure 4-3, page 4-12.
2. *Orient the instrument:* Set the MTX100B so its bottom is down on the work surface and its right side is facing you.
3. *Remove the A20 PCI Backplane board:* See Figure 4-10 on page 4-22.
  - a. Remove the interface module as described on page 4-23 (if needed).
  - b. Remove the A12 Main board as described on page 4-23.
  - c. Remove the CPU board as described on page 4-24.

- d. Disconnect these cables:
    - The cable from the A40 AC Distributor board at J220.
    - The cable from the 12 V main power supply at J160 and J170.
    - The cable from the external fan at J190.
    - The cable from the internal fan at J180.
    - The cables from the Front-Panel Processor board at J240.
    - The cable from the hard disk drive.
  - e. Use a screwdriver with a T-10 Torx tip to remove the ten screws securing the A20 PCI Backplane board to the chassis.
  - f. Lift the board up and away from the chassis.
4. *Reinstallation:* Perform step 3 in reverse order to reinstall the A20 PCI Backplane board.

### **Printer Connector**

1. *Assemble equipment and locate modules to be removed:*
  - a. You need a screwdriver with a  $\frac{1}{4}$  inch nut driver.
  - b. Locate the connector in the locator diagram Board *modules*, Figure 4-3, page 4-12.
2. *Orient the instrument:* Set the MTX100B so its bottom is down on the work surface and its rear is facing you.
3. *Remove the Printer connector:* See figure 4-10 on page 4-22.
  - a. Remove the interface module as described on page 4-23 (if needed).
  - b. Remove the A12 Main board as described on page 4-23.
  - c. Disconnect the cable from CN3 on the CPU board.
  - d. Use a  $\frac{1}{4}$  inch nut driver to unscrew the two hex-headed mounting posts securing the connector to the chassis.
  - e. Pull the connector away from the chassis.
4. *Reinstallation:* Perform step 3 in reverse order to reinstall the Printer connector.

## Procedure for Internal Modules

Perform the *Access Procedure* (on page 4-14) before doing any procedure in this group. The procedures are:

- *Hard disk drive*
- *Internal and external fans*
- *12 V main power supply*
- *A40 AC Distributor board*
- *RFI filter*

### Hard Disk Drive

1. *Assemble equipment and locate module to be removed:*
  - a. You need a screwdriver with a T-10 Torx tip.
  - b. Locate the hard disk drive in the locator diagram *Internal modules*, Figure 4-4, page 4-13.
2. *Orient the instrument:* Set the MTX100B so its bottom is down on the work surface and its left side is facing you.
3. *Remove the hard disk drive:* See Figure 4-11 on page 4-27.
  - a. Disconnect two cables from the hard disk drive.
  - b. Use a screwdriver with a T-10 Torx tip to remove the two screws securing the hard disk drive retainer to the chassis.
  - c. Grasp the hard disk drive with the plate, and pull it gently away from the chassis.
  - d. Remove the two screws securing the plate to the hard disk drive.
4. *Reinstallation:* Perform step 3 in reverse order to reinstall the hard disk drive.

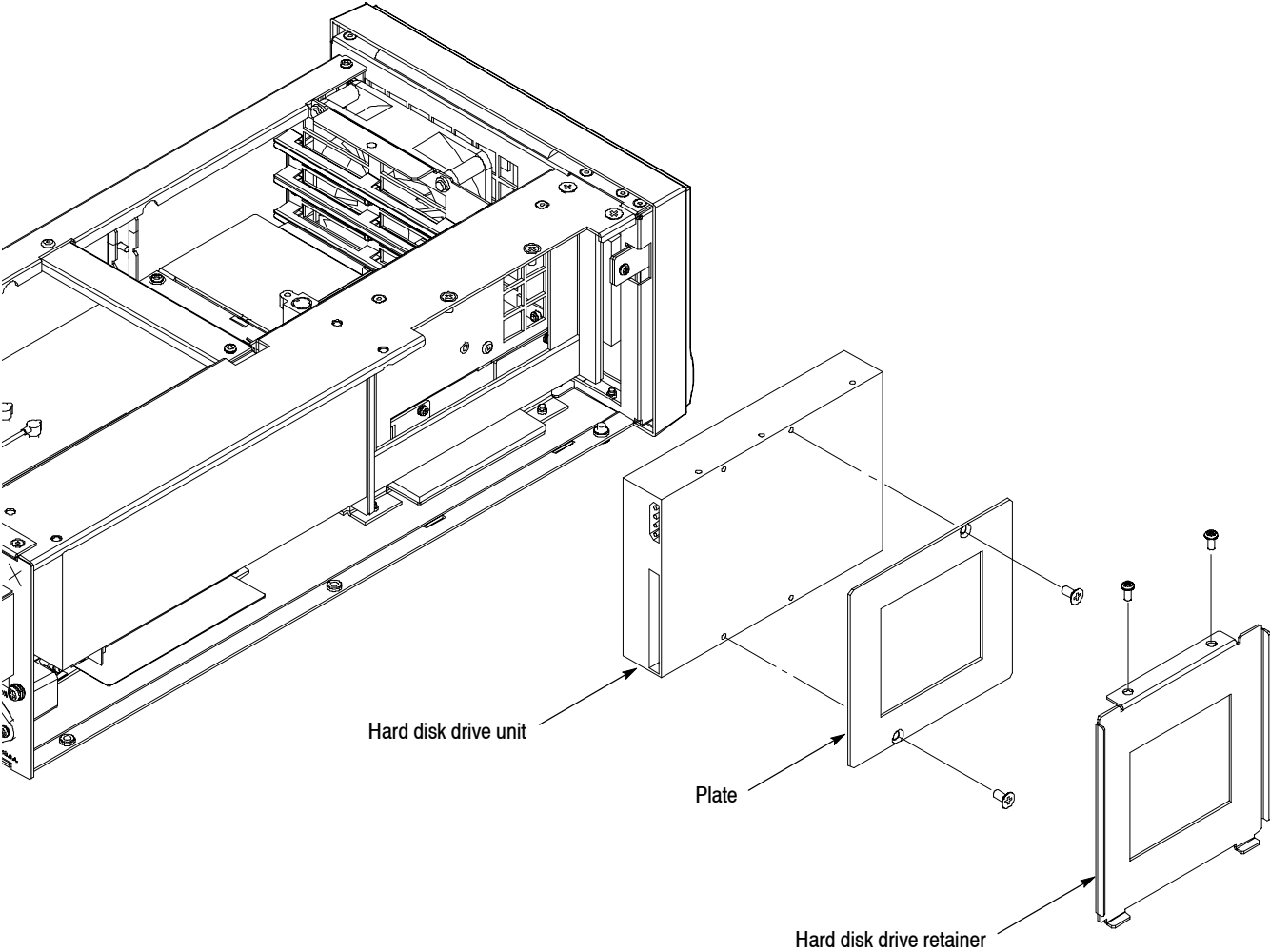

Figure 4-11: Hard disk drive removal

**Performing the Performance Verification and Running Sysprep.** If you replace the hard disk drive, you must perform the following steps:

1. Perform the performance verification procedures (refer to *Performance Verification* on page 3-1)
2. Run the sysprep batch file:
  - a. Select **File > Exit** to exit the MTX100B application. The Windows XP desktop appears.
  - b. Select **Start > Run** to open the Run dialog box.
  - c. Click the **Browse** button.
  - d. Select **C:\Sysprep\sysprep.bat**.
  - e. Click the **OK** button.

---

**NOTE.** After you replace the hard disk drive, you need to copy sample stream files from the *Sample Streams CD-ROM* on the *D:* drive of the hard disk drive.

---

## Internal and External Fans

1. *Assemble equipment and locate modules to be removed:*
  - a. You need a screwdriver with a T-10 Torx tip.
  - b. Locate the fans in the locator diagram *Internal modules*, Figure 4-4, page 4-13.
2. *Orient the instrument:* Set the MTX100B so its bottom is down on the work surface and its front is facing you.
3. *Remove the internal fan:* See Figure 4-12 on page 4-29.
  - a. Disconnect the cable from J180 on the A20 PCI Backplane board.
  - b. Remove the two rivets securing the fan to the chassis.
  - c. Lift the fan up out of the chassis.
4. *Reinstallation:* Perform step 3 in reverse order to reinstall the internal fan.
5. *Remove the external fan:* See Figure 4-12 on page 4-29.
  - a. Set the MTX100B so its bottom is down on the work surface and its rear is facing you.
  - b. Disconnect the cable from J190 on the A20 PCI Backplane board.
  - c. Use a screwdriver with a T-10 Torx tip to remove the four screws securing the fan and fan cover to the chassis.



6. *Reinstallation:* Perform step 5 in reverse order to reinstall the external fan.

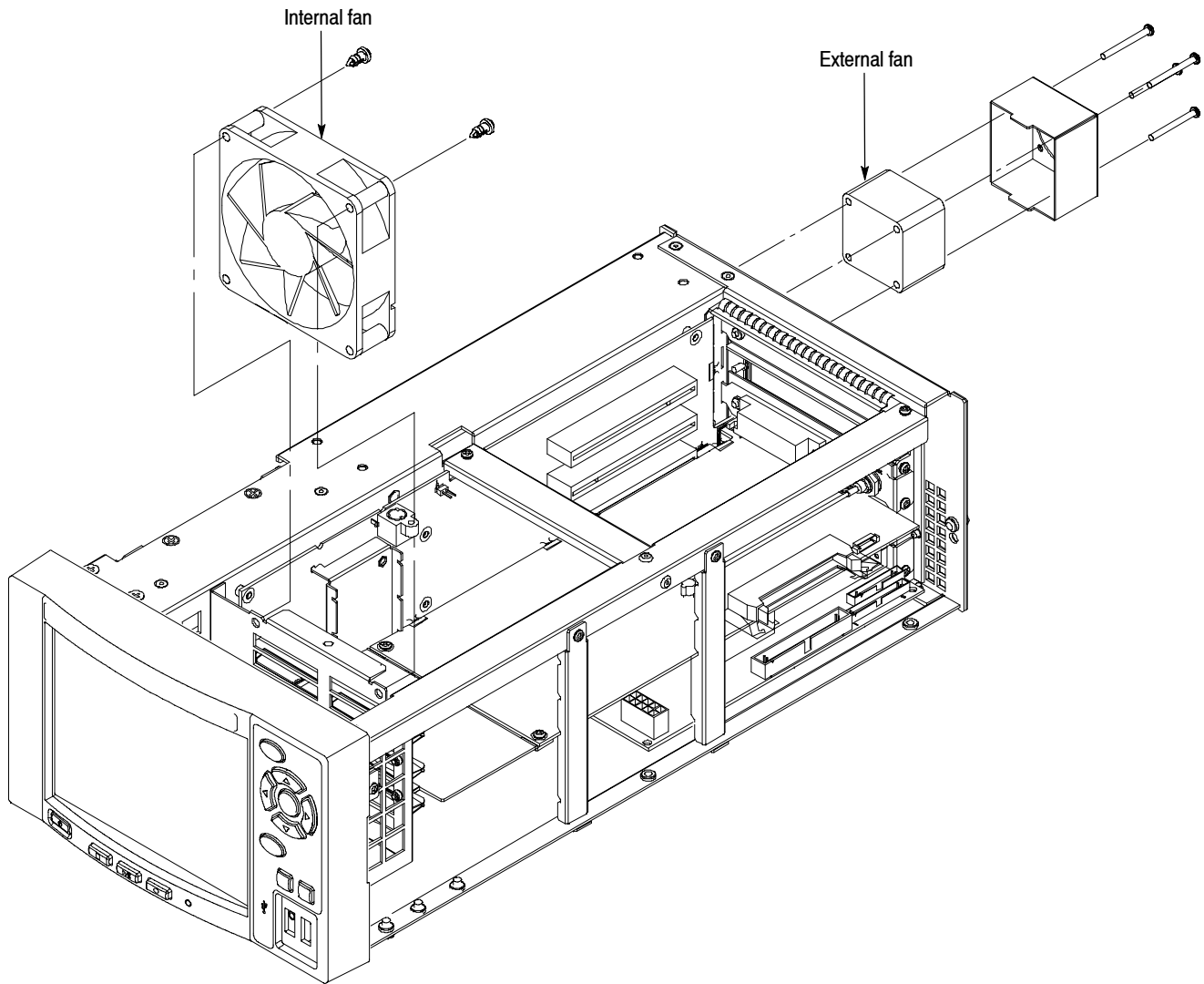

**Figure 4-12: Internal and external fan removal**

### **12 V Main Power Supply**

1. *Assemble equipment and locate modules to be removed:*
  - a. You need a screwdriver with a T-10 Torx tip.
  - b. Locate the 12 V main power supply in the locator diagram *Internal modules*, Figure 4-4, page 4-13.
2. *Orient the instrument:* Set the MTX100B so its bottom is down on the work surface and its left side is facing you.
3. *Remove the 12 V main power supply:* See Figure 4-13 on page 4-31.
  - a. Disconnect the cables from CN1, CN2, CN3, and CN4.
  - b. Use a screwdriver with a T-10 Torx tip to remove the four screws securing the 12 V main power supply to the chassis.
  - c. Lift the power supply away from the chassis.
4. *Reinstallation:* Perform step 3 in reverse order to reinstall the 12 V main power supply.

### **A40 AC Distributor Board**

1. *Assemble equipment and locate modules to be removed:*
  - a. You need a screwdriver with a T-10 Torx tip.
  - b. Locate the A40 AC Distributor board in the locator diagram *Internal modules*, Figure 4-4, page 4-13.
2. *Orient the instrument:* Set the MTX100B so its bottom is down on the work surface and its left side is facing you.
3. *Remove the A40 AC Distributor board:* See Figure 4-13 on page 4-31.
  - a. Disconnect the cables from J100, J110, and J120.
  - b. Use a screwdriver with a T-10 Torx tip to remove the three screws securing the A40 AC Distributor board to the chassis.
  - c. Lift the board away from the chassis.
4. *Reinstallation:* Perform step 3 in reverse order to reinstall the A40 AC Distributor board.

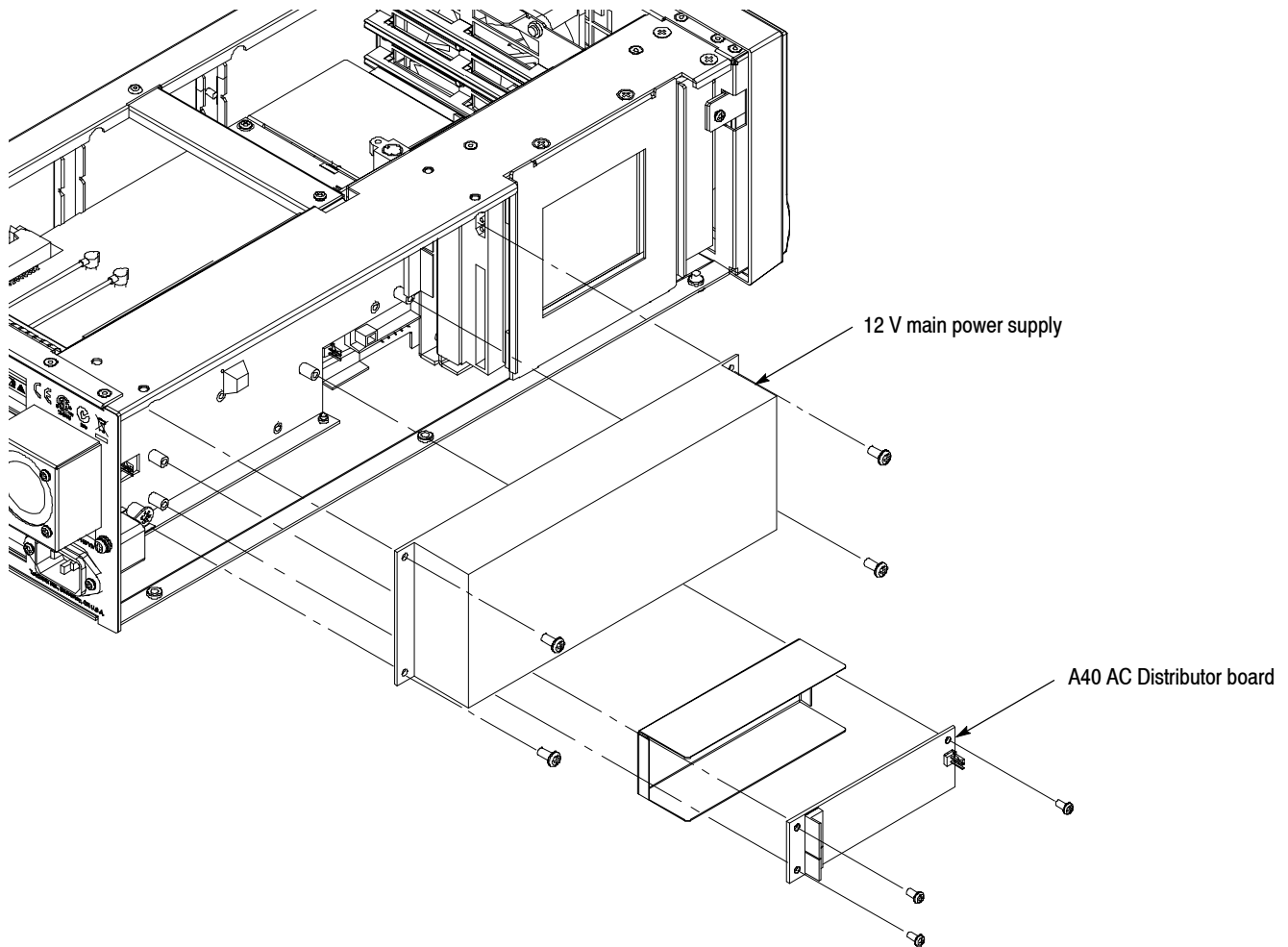
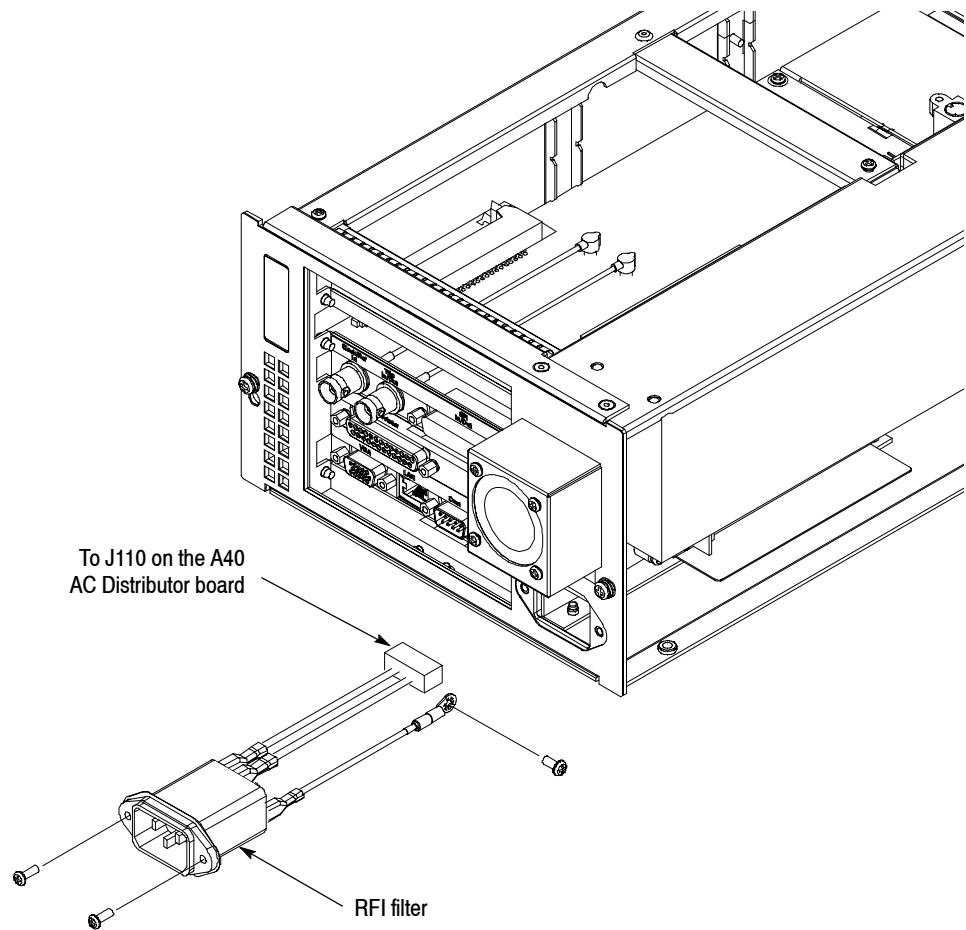

**Figure 4-13: 12 V main power supply and A40 AC Distributor board removal**

**RFI filter**

1. *Assemble equipment and locate modules to be removed:*
  - a. You need a screwdriver handle, a T-10 Torx tip, and a T-15 Torx tip.
  - b. Locate the RFI filter in the locator diagram *Internal modules*, Figure 4-4, page 4-13.
2. *Orient the instrument:* Set the MTX100B so its bottom is down on the work surface and its rear is facing you.

3. *Remove the RFI filter:* See Figure 4-14.
  - a. Disconnect the two cables from the RFI filter.
  - b. Use a screwdriver with a T-15 Torx tip to remove the screw securing the ground lead to the chassis.
  - c. Use a screwdriver with a T-10 Torx tip to remove the two screws securing the RFI filter to the chassis.
  - d. Pull the RFI filter away from the chassis.
4. *Reinstallation:* Perform step 3 in reverse order to reinstall the RFI filter.



**Figure 4-14: RFI filter removal**

# Verifying the BIOS Configuration

This section provides information needed to verify or set the BIOS configuration.

## Procedure



---

**CAUTION.** *It is very important to follow this procedure exactly or the instrument will not operate correctly.*

---

Perform the following procedure to set the BIOS configuration:

1. Connect the USB keyboard to the USB connector on the front panel.
2. Power on the instrument, and then press the **Del** key immediately. The **AwardBIOS CMOS Setup Utility screen** appears.
3. Set the BIOS configuration as follows. Use the arrow keys to highlight each item, and then press the **Enter** key to select it.

### Under Standard CMOS Features

Drive A : **None**

### Advanced Bios Features

First Boot Device : **HDD-0**  
Second Boot Device : **USB-CDROM**  
Third Boot Device : **USB-HDD**

### Advanced Chipset Features

Boot Display : **CRT+LFP**  
Panel Number : **1024X768**

### Integrated Peripherals

Super IO Device : Onboard FDC Controller : **Disabled**  
Onboard Serial Port 2 : **Disabled**  
Onboard Serial Port 4 : **Disabled**

### PC Health Status

CPU Warning Temperature : **Disabled**  
Shutdown Temperature : **Disabled**

4. Use the arrow keys to select **Save & Exit Setup**, and then press the **Enter** key. The Save to CMOS and Exit (Y/N)? message appears.
5. Enter **Y**, and press the **Enter** key.



# Troubleshooting

This subsection contains information about troubleshooting trees designed to isolate faulty modules in the MTX100B.

## Troubleshooting Trees

Figures 4-15 through 4-23 show the troubleshooting procedure for the MTX100B.

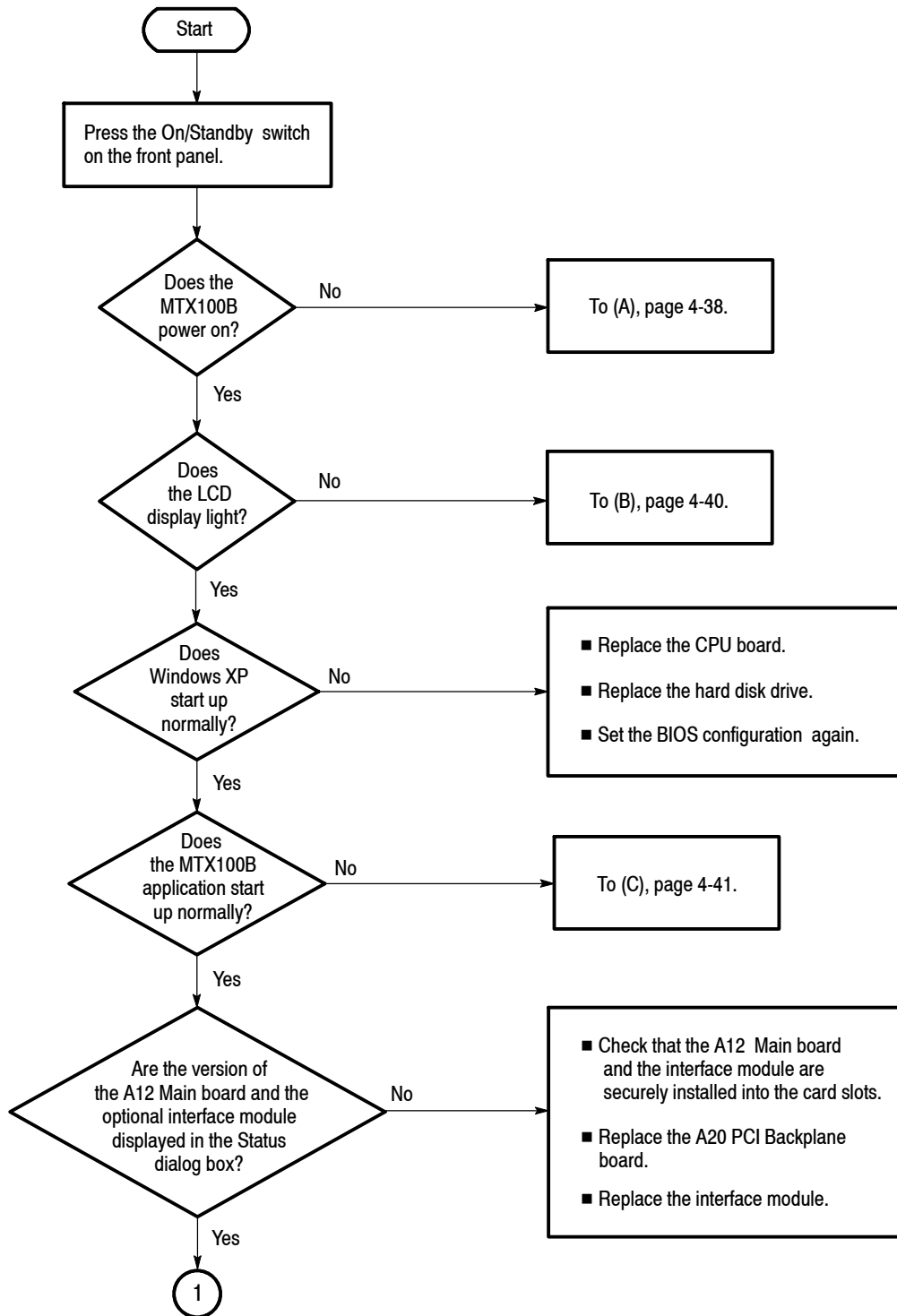

Figure 4-15: Troubleshooting procedure (1)



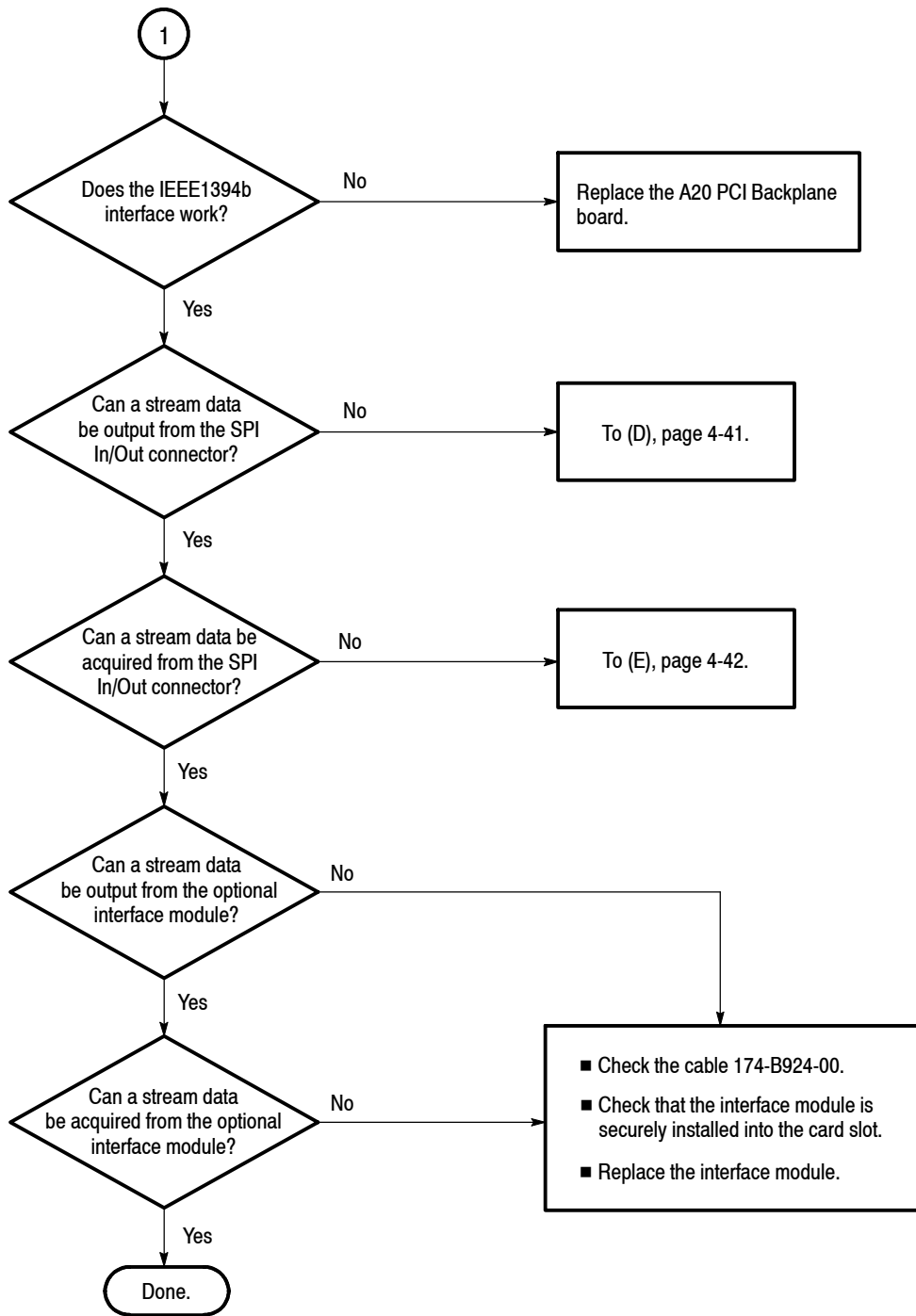

Figure 4-16: Troubleshooting procedure (2)

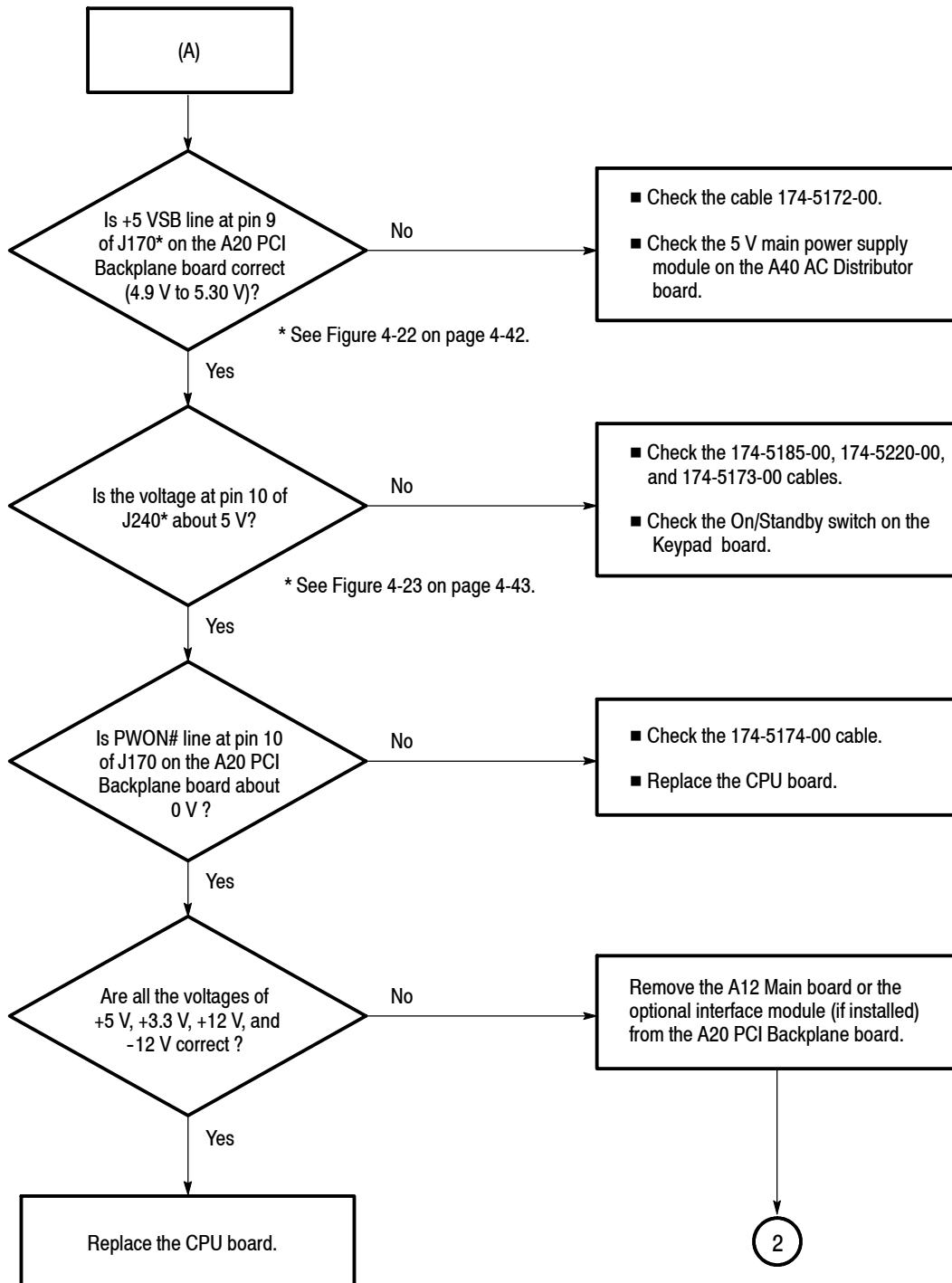
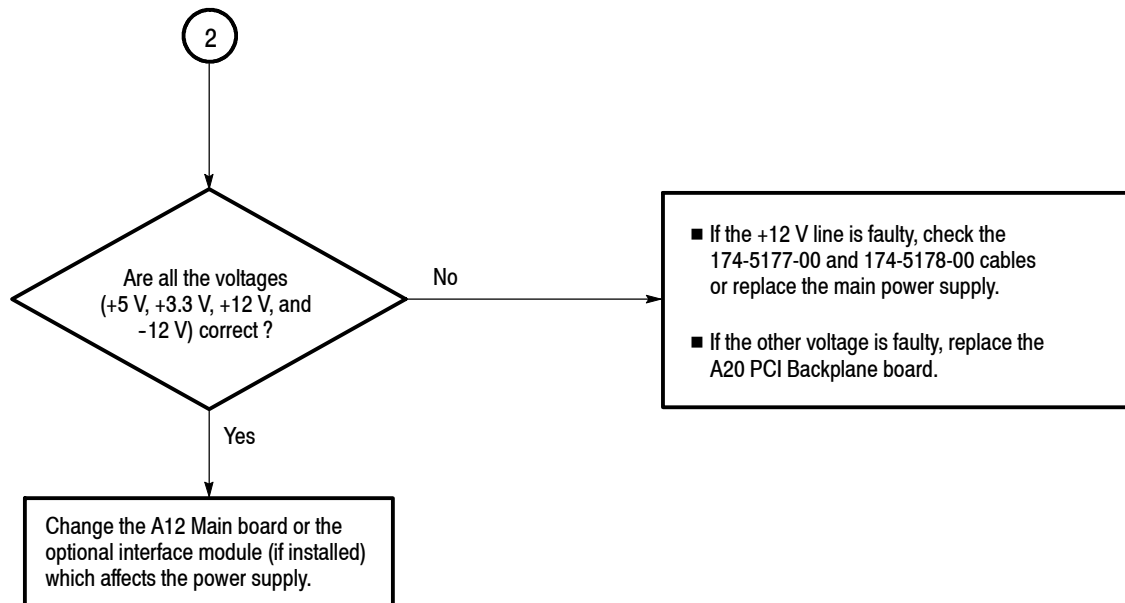
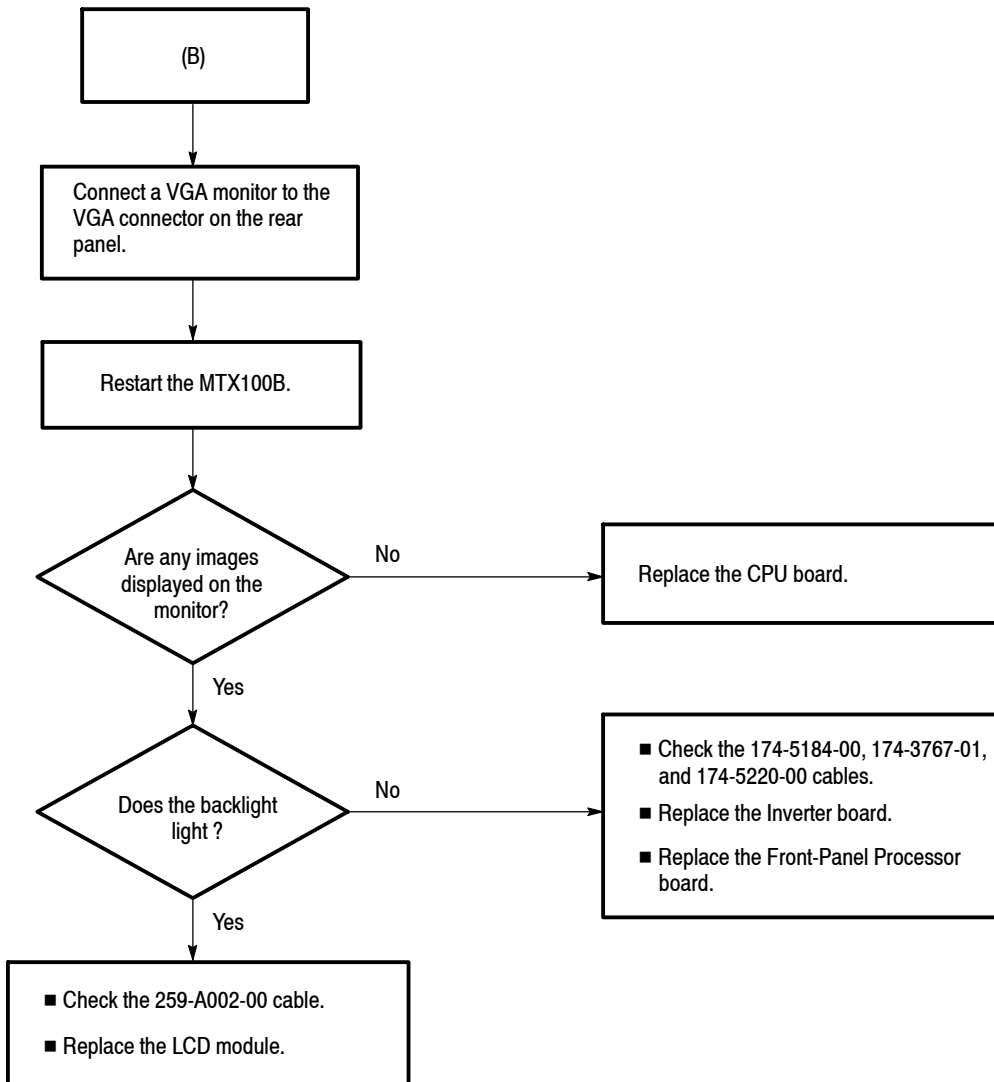

Figure 4-17: Troubleshooting procedure (3)



**Figure 4-18: Troubleshooting procedure (4)**



**Figure 4-19: Troubleshooting procedure (5)**

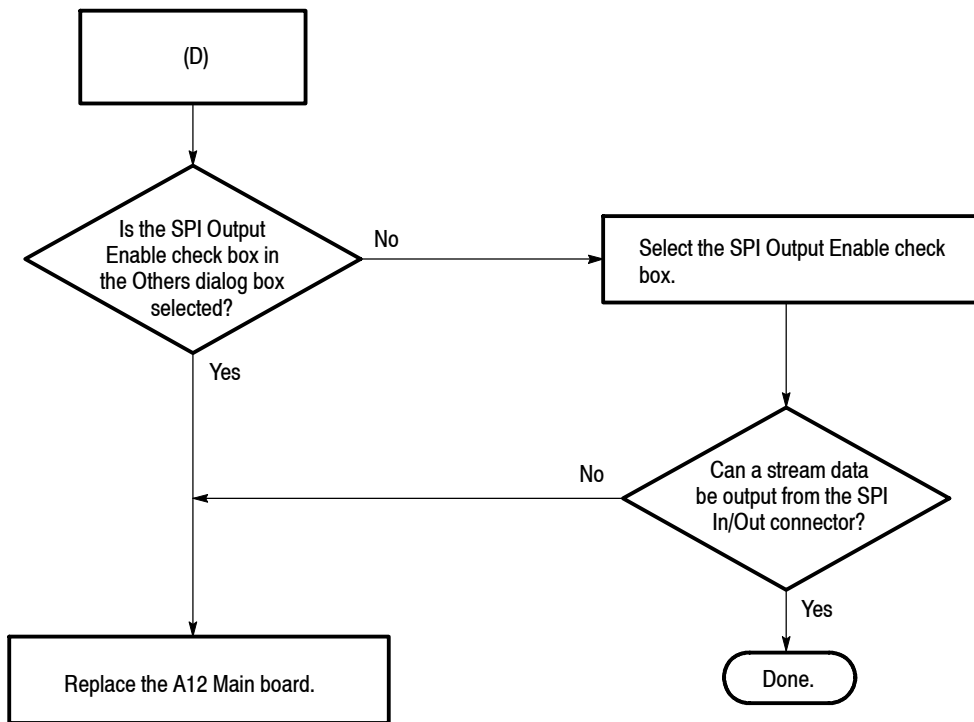
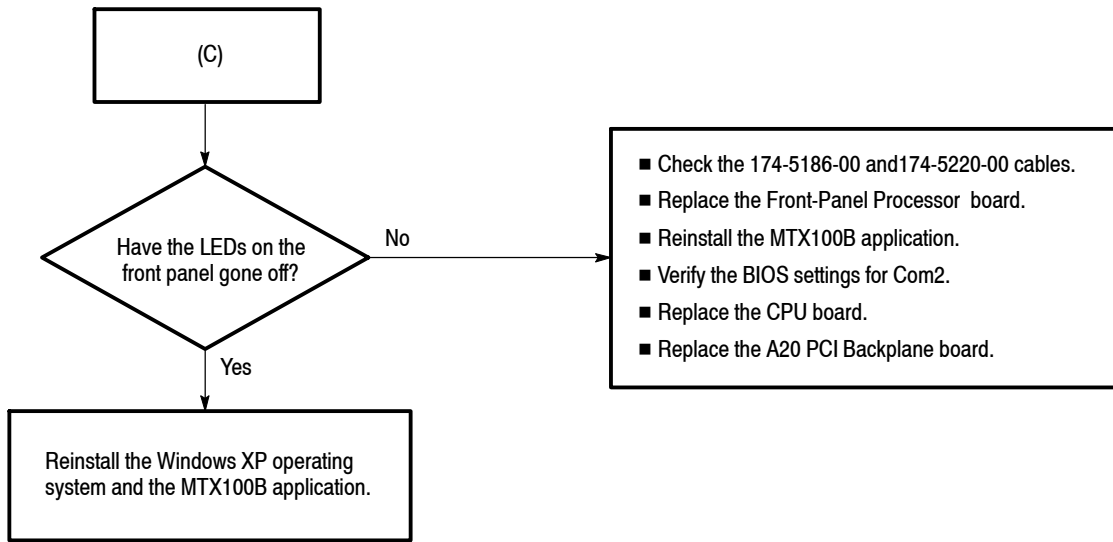

Figure 4-20: Troubleshooting procedure (6)

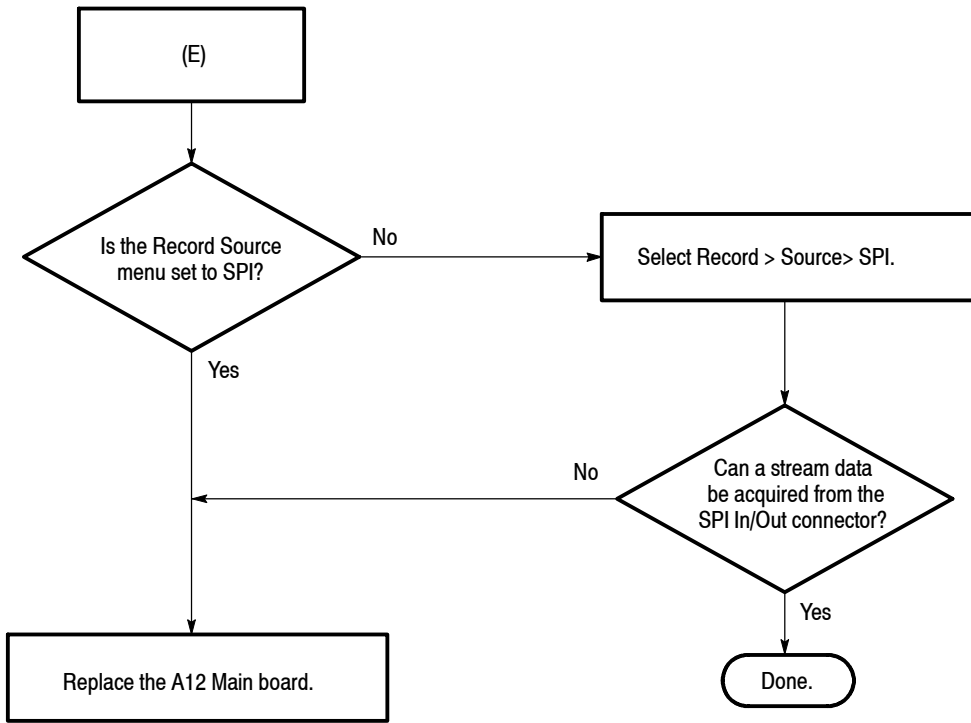

Figure 4-21: Troubleshooting procedure (7)

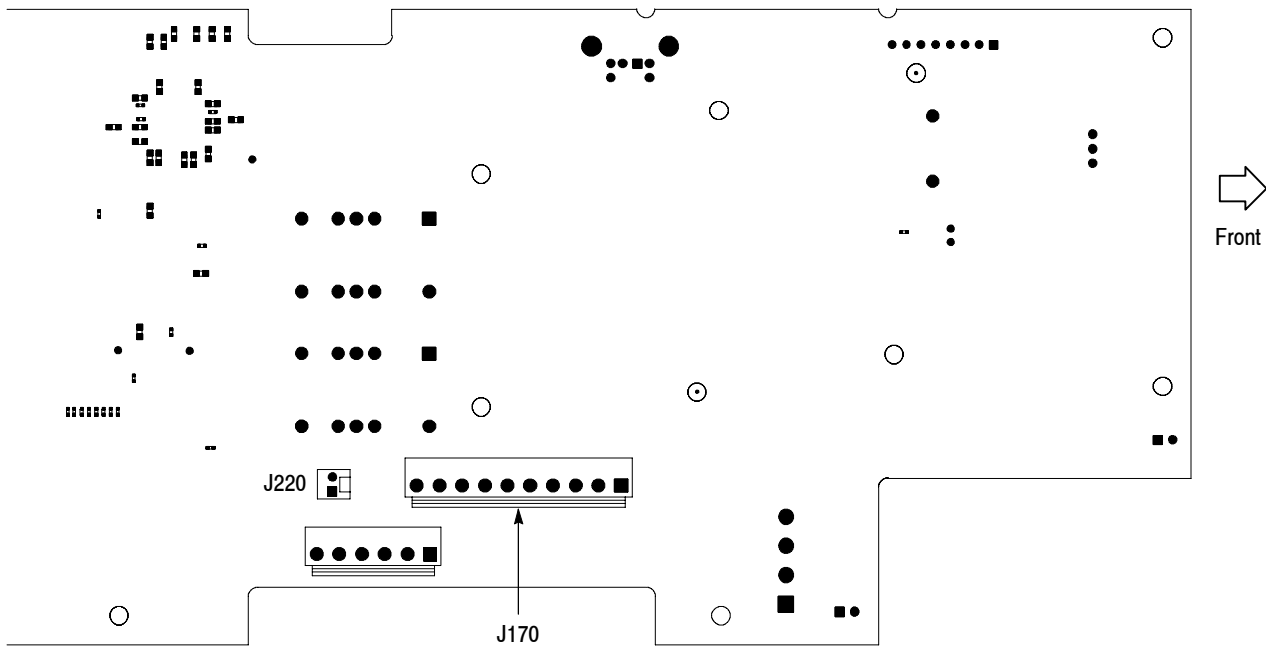

Figure 4-22: A20 PCI Backplane board view- back side

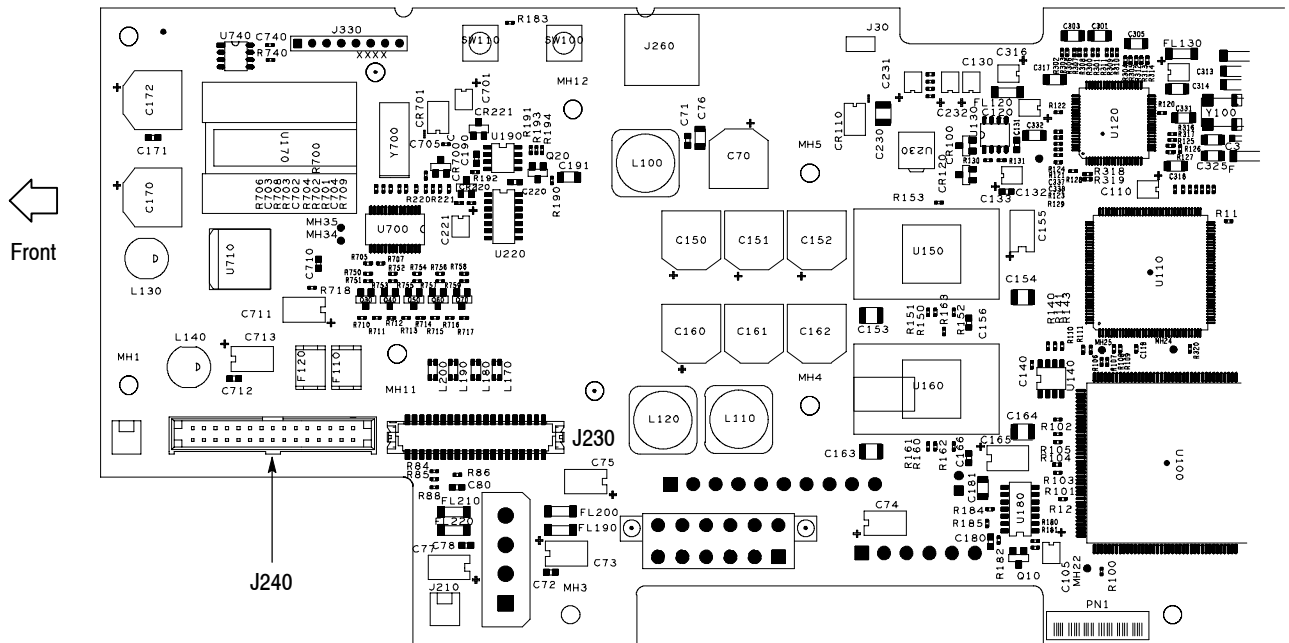

Figure 4-23: A20 PCI Backplane board view-right side





# System Software Recovery

If the MTX100B does not boot up or is corrupted, you can recover the system software by using this recovery procedure.



---

**CAUTION.** *Running the recovery procedure overwrites all the contents of the hard disk drive and resets the system to the factory defaults.*

---

The recovery can be performed in two ways:

- **Recover Boot Partition:** This permanently overwrites the contents of your boot partition. This mode of recovery is preferred if you want to keep your old data files on the D drive.
- **Recover Entire Drive:** This permanently overwrites the contents of your entire hard disk drive and resets the system to the factory defaults.

## Recovery Procedure

Perform the following procedure to recover the Windows XP and MTX100B application software:

1. Restart your system and press the **F4** key as soon as the BIOS tests are complete. This opens the Phoenix Always screen with the following options:
  - Restore System
  - System Information
2. Click **Restore System > Phoenix Recover Pro 6**.
3. Click **Advanced > Factory Restore** to replace the Windows XP and MTX100B application software from the backup created when the system was manufactured. A confirmation dialog box is displayed.
4. Click **OK** to restart your system and display the Phoenix Recover Pro 6 screen. This screen allows you to perform one of the following operations:
  - Click **Recover Boot Partition** or **Recover Entire Drive** to overwrite the data according to your requirements. A confirmation dialog box is displayed. Click **Yes** to continue.

A screen showing the progress of the recovery appears with the details of the time elapsed, time remaining, amount of data recovered, and total data to recover.



---

**CAUTION.** *Do not Cancel the recovery process once initiated. Cancelling the process will leave your hard disk drive in a partially recovered, unstable state.*

---

Immediately after the data is recovered, the system restarts and the Windows XP setup wizard is displayed.

- Click **Cancel and Exit** to cancel the recovery process and exit from the Phoenix Recovery Pro 6 application.
5. Click the **Next** button of the wizard until Windows XP is installed. The system restarts after the installation of Windows XP to display the MTX100B application screen.

# Using the Rescue Disc

The information in this section helps you to reinstall the Microsoft Windows XP and the MTX100B application software using the rescue DVD disc.

The prerequisites for the recovery procedure are as follows:

- Sony DRX-810UL external USB DVD drive
- Rescue DVD disc, Tektronix part number 063-3931-XX
- USB keyboard
- USB mouse

## Recovery Procedure

---

**NOTE.** *The rescue disc recovery procedure works only with the MTX100B, RTX100B, and RTX130B.*

---

Before you start the rescue disc recovery procedure make sure to check for the BIOS settings. Follow these steps to set the BIOS settings for booting from an external USB DVD drive:

1. Press **Del** when the initial BIOS screen appears.
2. Select **Advanced CMOS Feature** and set it to the following configuration:

First Boot Device=(USB\_CDROM)

Second Boot Device=(USB\_HDD)

Third Boot Device=(HDD\_0)

3. Press **F10** to save the CMOS configuration.

A message asking you to press Y to exit and N to continue is displayed.

4. Press **Y** to exit and restart the instrument.

Follow these steps to restore the Windows XP and MTX100B application software using the rescue disc:

1. Insert the rescue disc into the external USB DVD drive.
2. Connect the external USB DVD drive to port 1 and the USB keyboard to port 2 of the instrument, and then restart.

After the BIOS screens, the CD boots and scans for the USB drive. The following screen is displayed within a short period. You can press 1 to continue and 2 to abort the procedure and turn off the instrument. By default, option 2 is selected after a delay of 20 seconds.

```
MTX100B/RTX100B/RTX130B Disk Builder.
(C) 2006, Tektronix Inc. All Rights Reserved.

*****
*
* WARNING: THIS PROCEDURE WILL ***IRREVOCALLY*** reset your HardDisk to
* factory defaults
*
* This DVD should be run ONLY from an external USB-CDROM Drive.
* You are recommended to use a Sony DRX-8100L external drive.
*
* This DVD is for internal Tektronix usage only.
*
* This package installs:      Version 9.0,   Built on : 27 June 2006
*
* Are you sure you want to proceed?
*
* Press 1 to continue.
* Press 2 to ABORT.
*
*****
[1,2]:
```

3. Press 1 to proceed as soon as you see the screen.

---

**NOTE.** The approximate time taken to restore the Windows XP and MTX100B application is 1 hr to 1.5 hr.

---

4. Press any key to turn off the instrument once the restoration is complete.
5. Disconnect the external USB DVD drive from the instrument and restart.  
The Windows XP setup wizard is displayed.
6. Click the **Next** button of the wizard until Windows XP is installed. The system restarts after the installation of Windows XP to display the MTX100B application screen.



# Options



# Options

This section describes options that are available for the MTX100B.

The following options are available:

<b>Options</b>	<b>Description</b>
<b>Interface options</b>	
Option 01	Adds the ASI interface
Option 02	Adds the universal parallel/serial interface
Option 05	Adds the IEEE1394/ASI interface
Option 07	Adds the SMPTE310M/ASI/SPI interface
<b>Software option</b>	
Option SC	Adds the Scheduler software
Option IPE	Adds 10/100 Base-T Video over IP electrical interface
Option MX	Adds Deferred Time Multiplexer
Option ES	Adds ES Analyzer
Option PB	Adds PES & Buffer Analyzer
Option DB	Adds Carousel Analyzer
Option CG	Adds Carousel Generator
Option DBCG	Adds Carousel Analyzer & Carousel Generator
Option TSCA	Adds Transport Stream Compliance Analyzer
Option TSCX	Adds real-time Transport Stream Compliance Analyzer
<b>Service options</b>	
Option D1	Provides calibration data
Option D3	Provides calibration data for 3 years
Option D5	Provides calibration data for 5 years
Option C3	Provides calibration services for 3 years
Option C5	Provides calibration services for 5 years
Option R3	Extends the instrument warranty to 3 years
Option R5	Extends the instrument warranty to 5 years

<b>Options</b>	<b>Description</b>
<b>Power cord options</b>	
Option A0	North America power cord
Option A1	Universal Euro power cord
Option A2	United Kingdom power cord
Option A3	Australia power cord
Option A4	240 V North America power cord
Option A5	Switzerland power cord
Option A6	Japan power cord
Option A10	China power cord
Option A99	No power cord





# Diagrams



# Diagrams

This section contains the following diagrams:

- Block diagram of the MTX100B
- Interconnect diagram of the MTX100B

Block diagram shows the modules and functional blocks in the MTX100B.  
Interconnect diagram shows how the modules in the MTX100B connect together.



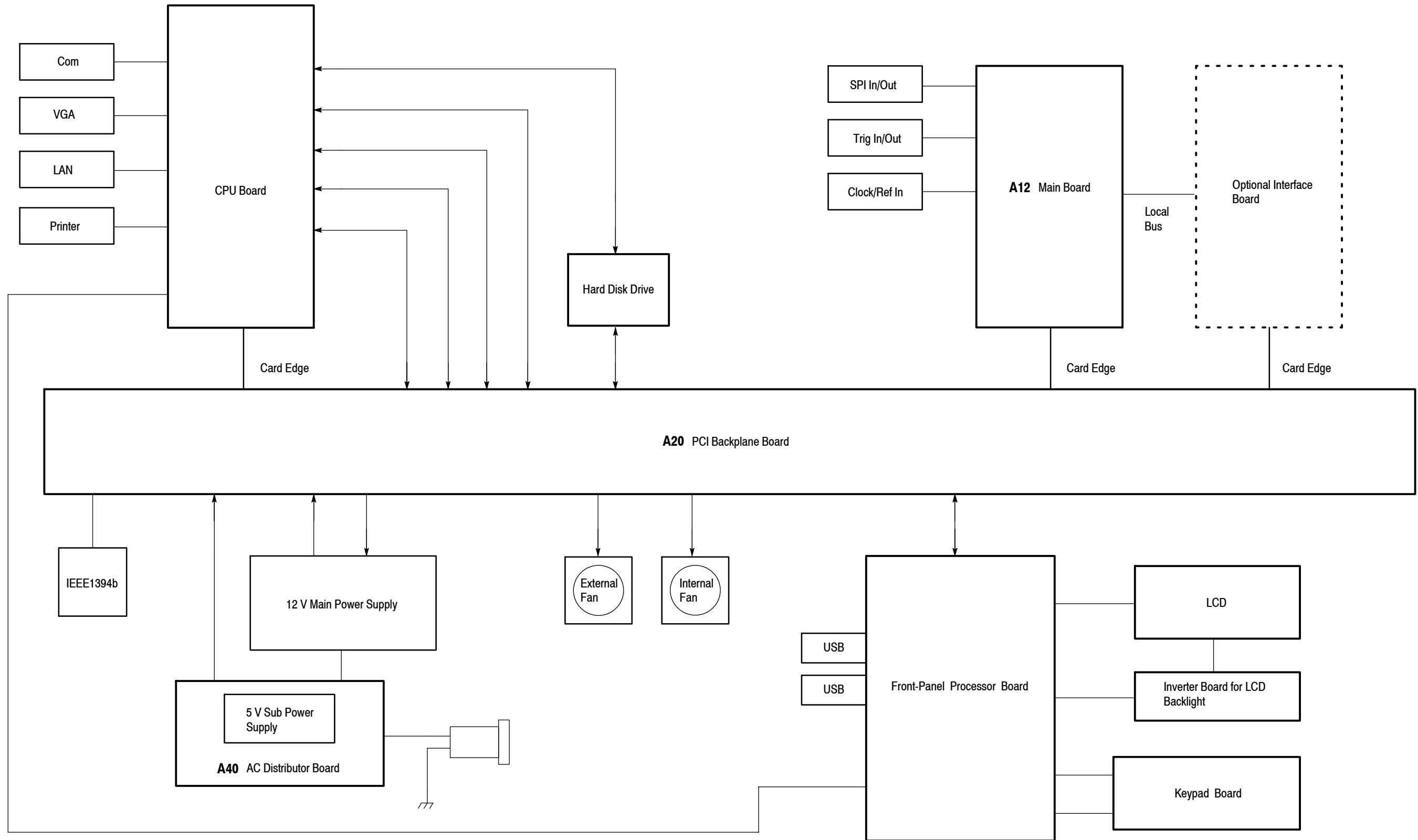

Figure 6-1: MTX100B block diagram



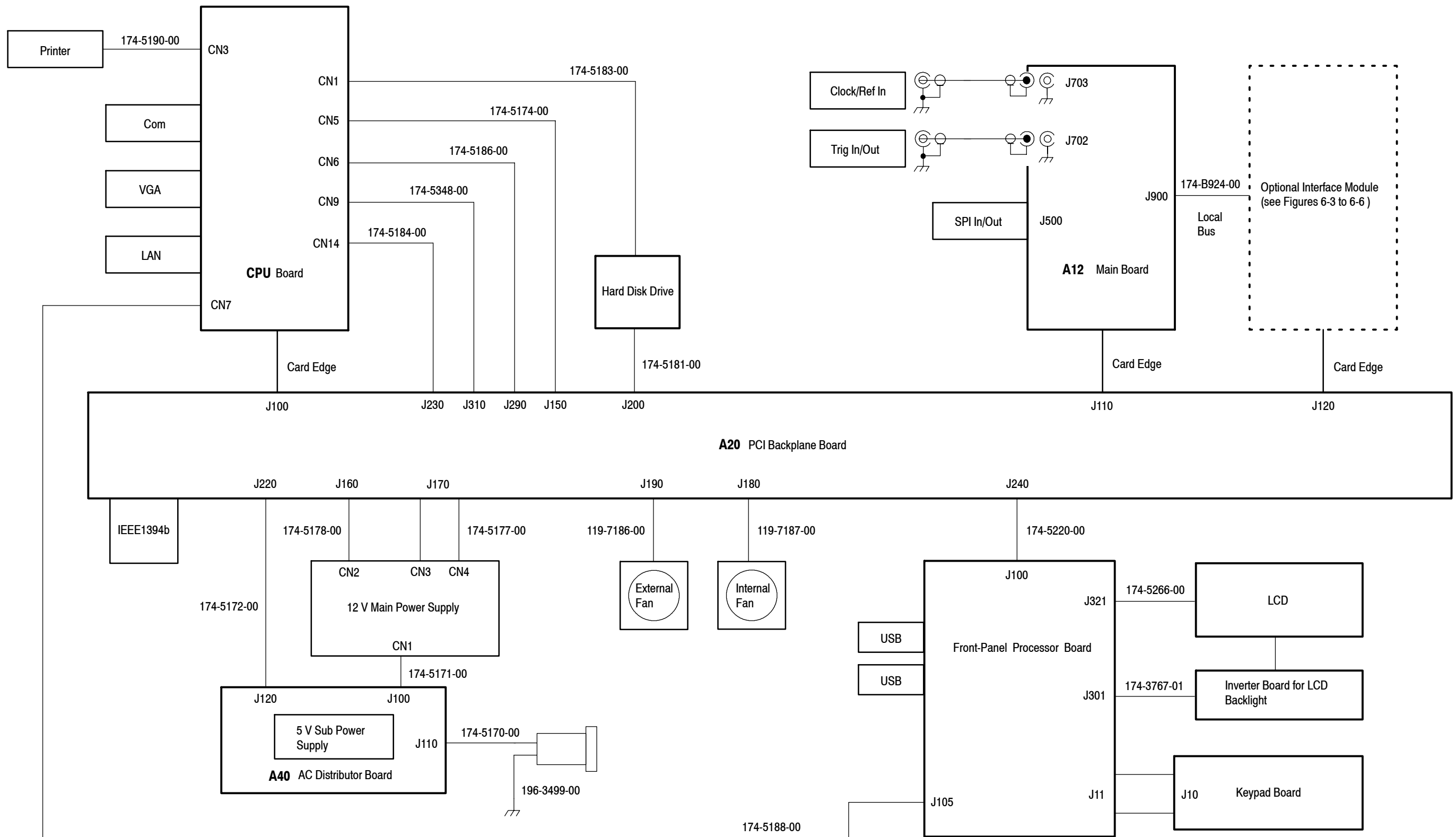

Figure 6-2: MTX100B interconnect diagram





# Diagrams of the Optional Modules

This section contains the interconnect diagrams of the optional interface modules.

## A100 ASI Interface Module (Option 01)

Figure 6-3 shows the A100 ASI Interface module and how it interconnects with the A20 PCI Backplane board and the A12 Main board.

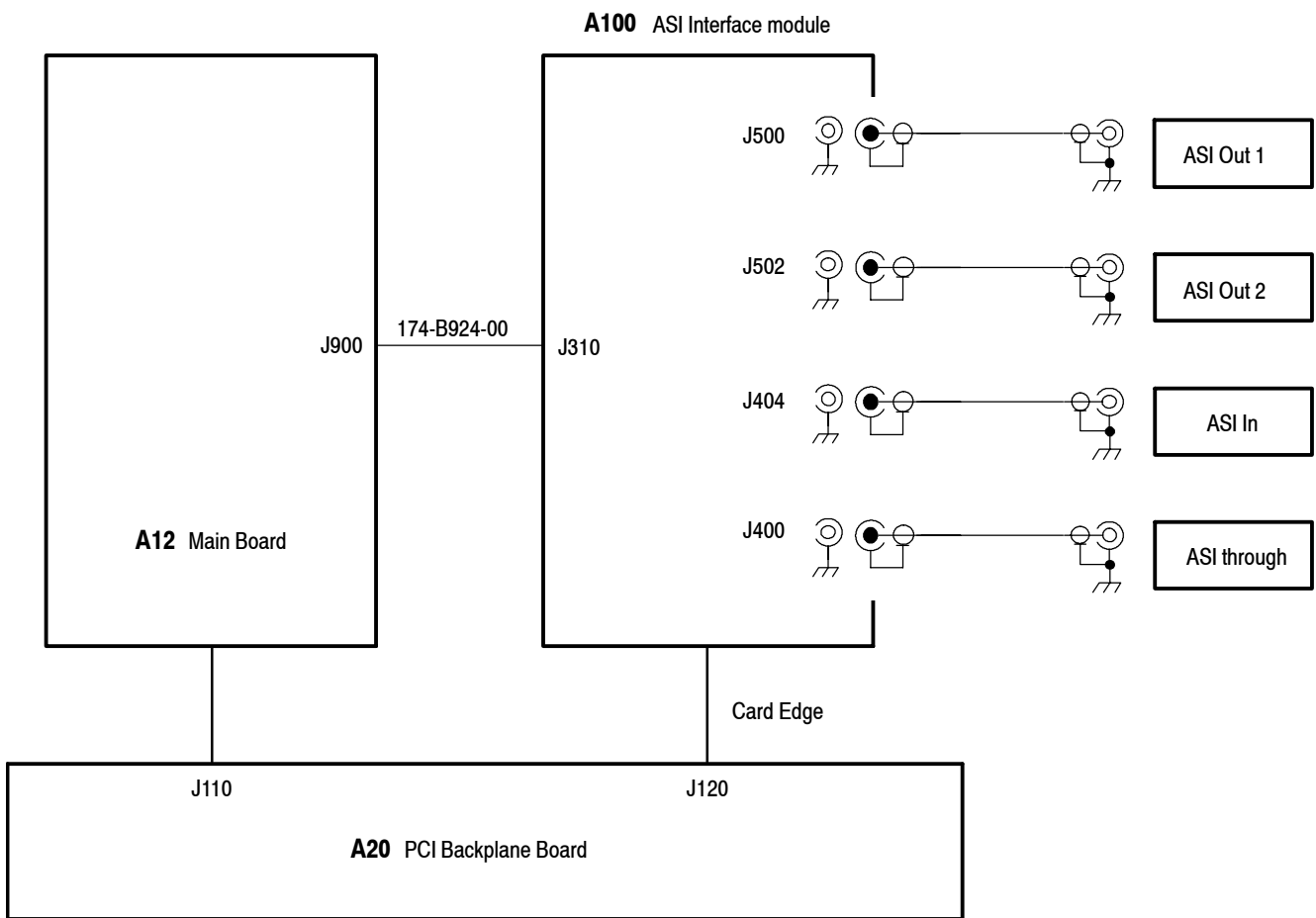

Figure 6-3: A100 ASI Interface module connections

## A110 Universal Parallel/Serial Interface Module (Option 02)

Figure 6-4 shows the A110 Universal Parallel/Serial Interface module and how it interconnects with the A20 PCI Backplane board and the A12 Main board.

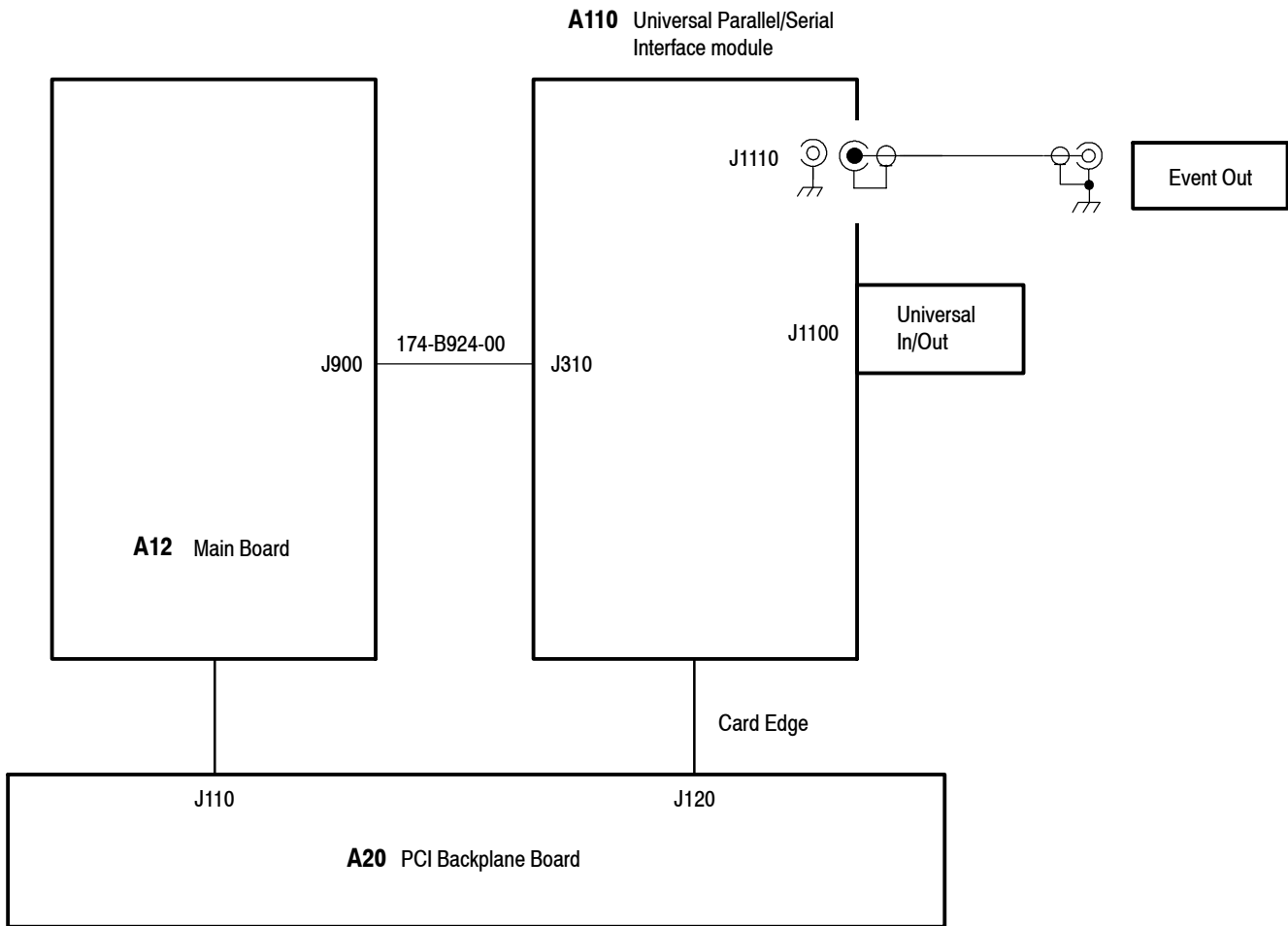

Figure 6-4: A110 Universal Parallel/Serial Interface module connections

## A140 IEEE1394/ASI Interface Module (Option 05)

Figure 6-5 shows the A140 IEEE1394/ASI Interface module and how it interconnects with the A20 PCI Backplane board and the A12 Main board.

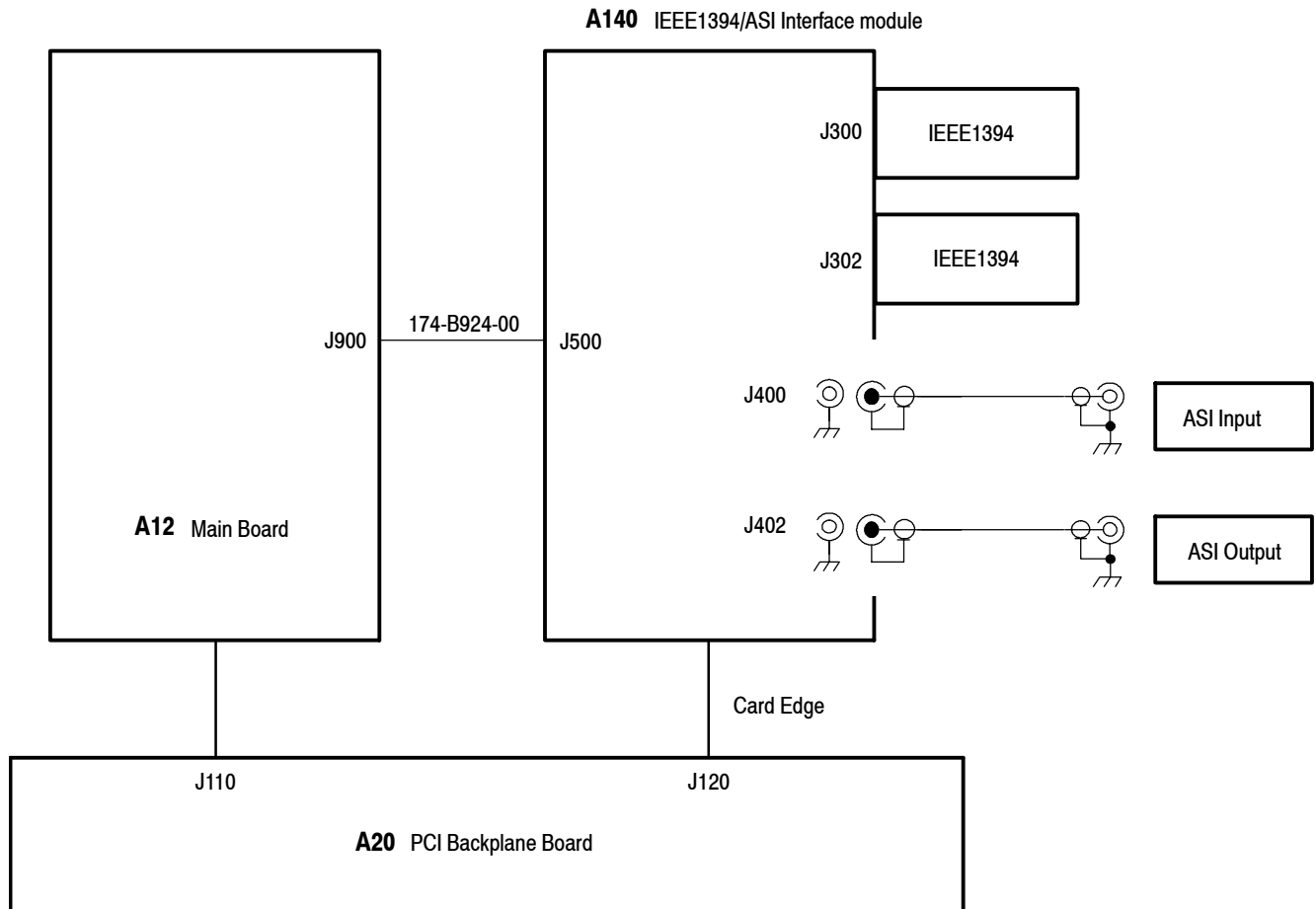

Figure 6-5: A140 IEEE1394/ASI Interface module connections

## A170 SMPTE310M/ASI/SPI Interface Module (Option 07)

Figure 6-6 shows the A170 SMPTE310M/ASI/SPI Interface module and how it interconnects with the A20 PCI Backplane board and the A12 Main board.

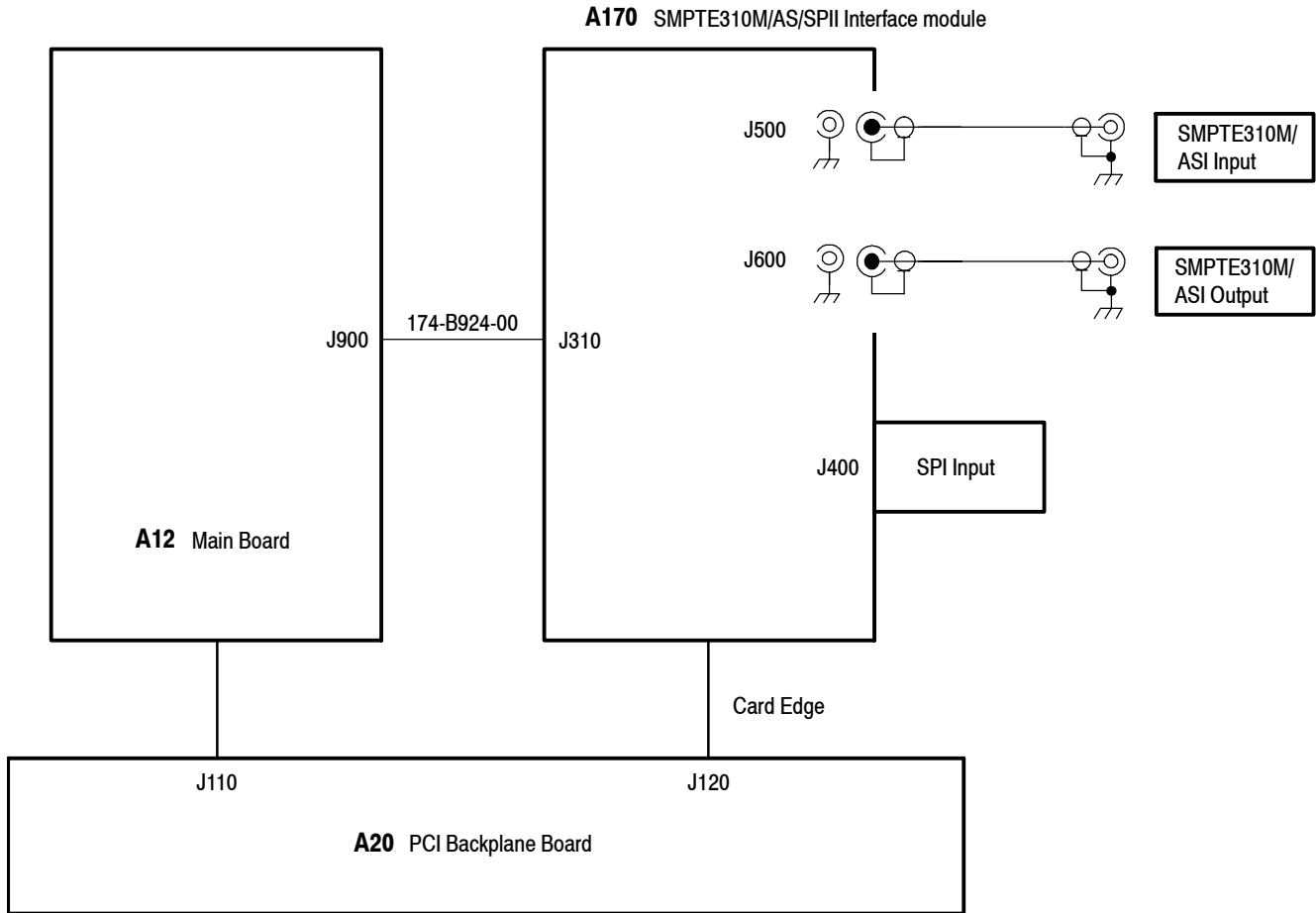

Figure 6-6: A170 SMPTE310M/ASI/SPI Interface module connections



# **Replaceable Parts List**



# Replaceable Parts List

This section contains a list of the replaceable modules for the MTX100B. Use this list to identify and order replacement parts.

## Parts Ordering Information

Replacement parts are available through your local Tektronix field office or representative.

Changes to Tektronix products are sometimes made to accommodate improved components as they become available and to give you the benefit of the latest improvements. Therefore, when ordering parts, it is important to include the following information in your order:

- Part number (see Part Number Revision Level below)
- Instrument type or model number
- Instrument serial number
- Instrument modification number, if applicable

If you order a part that has been replaced with a different or improved part, your local Tektronix field office or representative will contact you concerning any change in part number.

Change information, if any, is located at the rear of this manual.

### Part Number Revision Level

Tektronix part numbers contain two digits that show the revision level of the part. For most parts in this manual, you will find the letters XX in place of the revision level number.



When you order parts, Tektronix will provide you with the most current part for your product type, serial number, and modification (if applicable). At the time of your order, Tektronix will determine the part number revision level needed for your product, based on the information you provide.

**Module Servicing**

Modules can be serviced by selecting one of the following three options. Contact your local Tektronix service center or representative for repair assistance.

**Module Exchange.** In some cases you may exchange your module for a remanufactured module. These modules cost significantly less than new modules and meet the same factory specifications. For more information about the module exchange program, call 1-800-833-9200. Outside North America, contact a Tektronix sales office or distributor; see the Tektronix Web site for a list of offices: [www.tektronix.com](http://www.tektronix.com)

**Module Repair and Return.** You may ship your module to us for repair, after which we will return it to you.

**New Modules.** You may purchase replacement modules in the same way as other replacement parts.



## Using the Replaceable Parts List

This section contains a list of the mechanical and/or electrical components that are replaceable for the MTX100B. Use this list to identify and order replacement parts. The following table describes each column in the parts list.

### Parts list column descriptions

Column	Column name	Description
1	Figure & index number	Items in this section are referenced by figure and index numbers to the exploded view illustrations that follow.
2	Tektronix part number	Use this part number when ordering replacement parts from Tektronix.
3 and 4	Serial number	Column three indicates the serial number at which the part was first effective. Column four indicates the serial number at which the part was discontinued. No entries indicates the part is good for all serial numbers.
5	Qty	This indicates the quantity of parts used.
6	Name & description	An item name is separated from the description by a colon (:). Because of space limitations, an item name may sometimes appear as incomplete. Use the U.S. Federal Catalog handbook H6-1 for further item name identification.

**Abbreviations**      Abbreviations conform to American National Standard ANSI Y1.1-1972.

**Replaceable parts list**

<b>Fig. &amp; index number</b>	<b>Tektronix part number</b>	<b>Serial no. effective</b>	<b>Serial no. discont'd</b>	<b>Qty</b>	<b>Name &amp; description</b>
7-1-1	211-0374-00			6	SCREW,MACHINE:6-32X0.25,FLH,100 DEG,STL ZN-CM1,T10 TORX
-2	337-4345-00			1	SHIELD,ELEC:COVER,LEFT,MTX100A,AL
-3	390-1212-01			1	CABINET ASSY;WRAP AROUND HOUSING,0.050 AL,SILVERGRAY,W/FEET&HANDLE, SAFETY CONTROLLED
-4	211-0711-00			2	SCR,ASSEM WSHR;6-32X0.250,PNH,STL,CDPL,T-15 TORX DR,MACHINE,W/SQ CONE WASHER
-5	335-1374-00			1	MARKER,IDENT;LABEL,MKD WARNING TO AVOID ELECTRIC,50.8MMX25.4MM,0.002 POLYESTER(3M 7982),OVER LAMINATE W/0.001 FLEVCON,W/ADHESIVE BACK, SAFETY CONTROLLED
-6	063-3868-00			1	SOFTWARE PKG;MICROSOFT WINDOWS XP PROFESSIONAL,INCLUDES SERVICE PACK 2,1-2 PROCESSOR VERSION;CERTIFICATE OF AUTHENTICITY
-7	337-4346-00			1	SHIELD,ELEC:COVER,RIGHT,MTX100A,AL
-8	211-0374-00			7	SCREW,MACHINE:6-32X0.25,FLH,100 DEG,STL ZN-CM1,T10 TORX

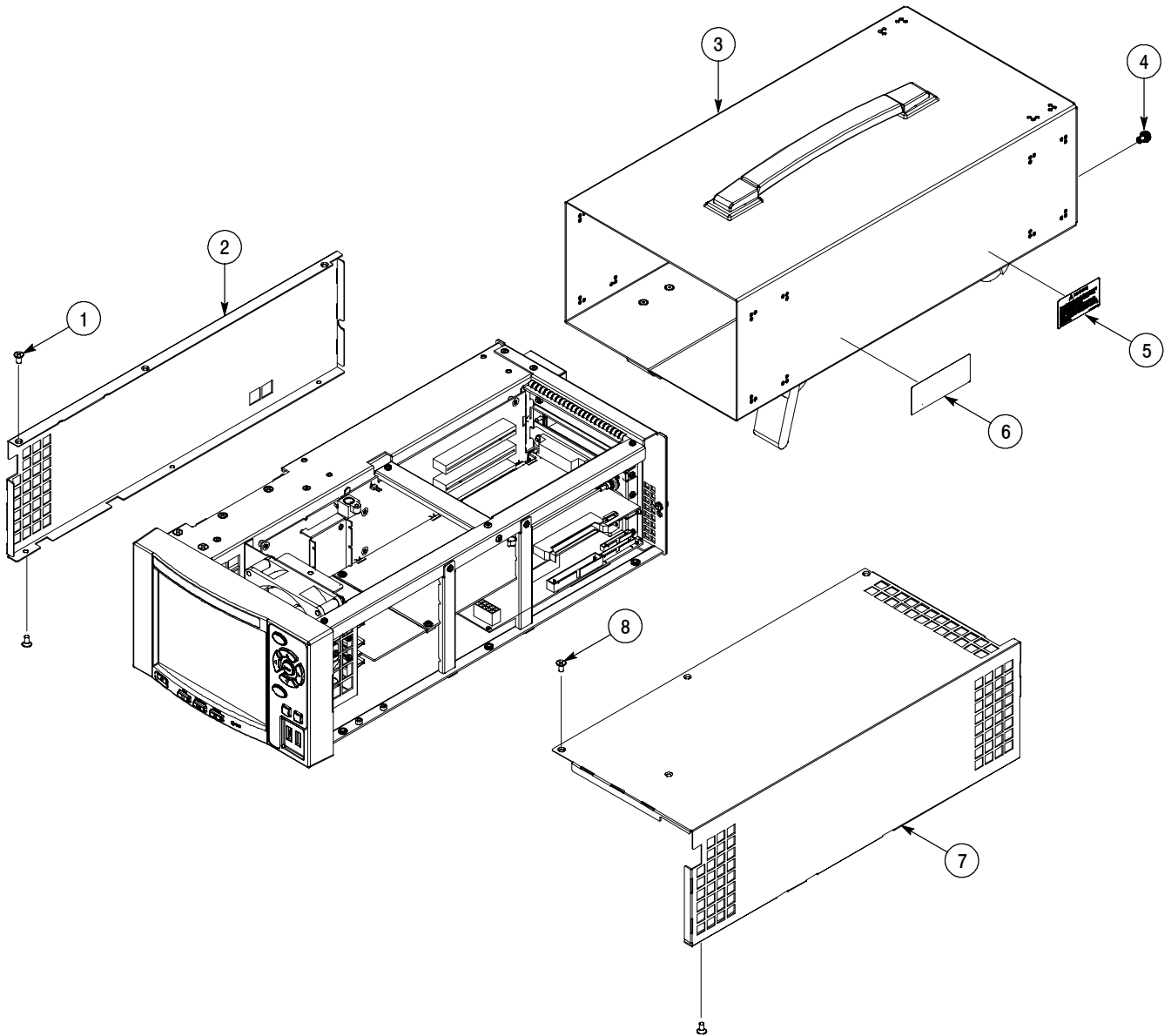
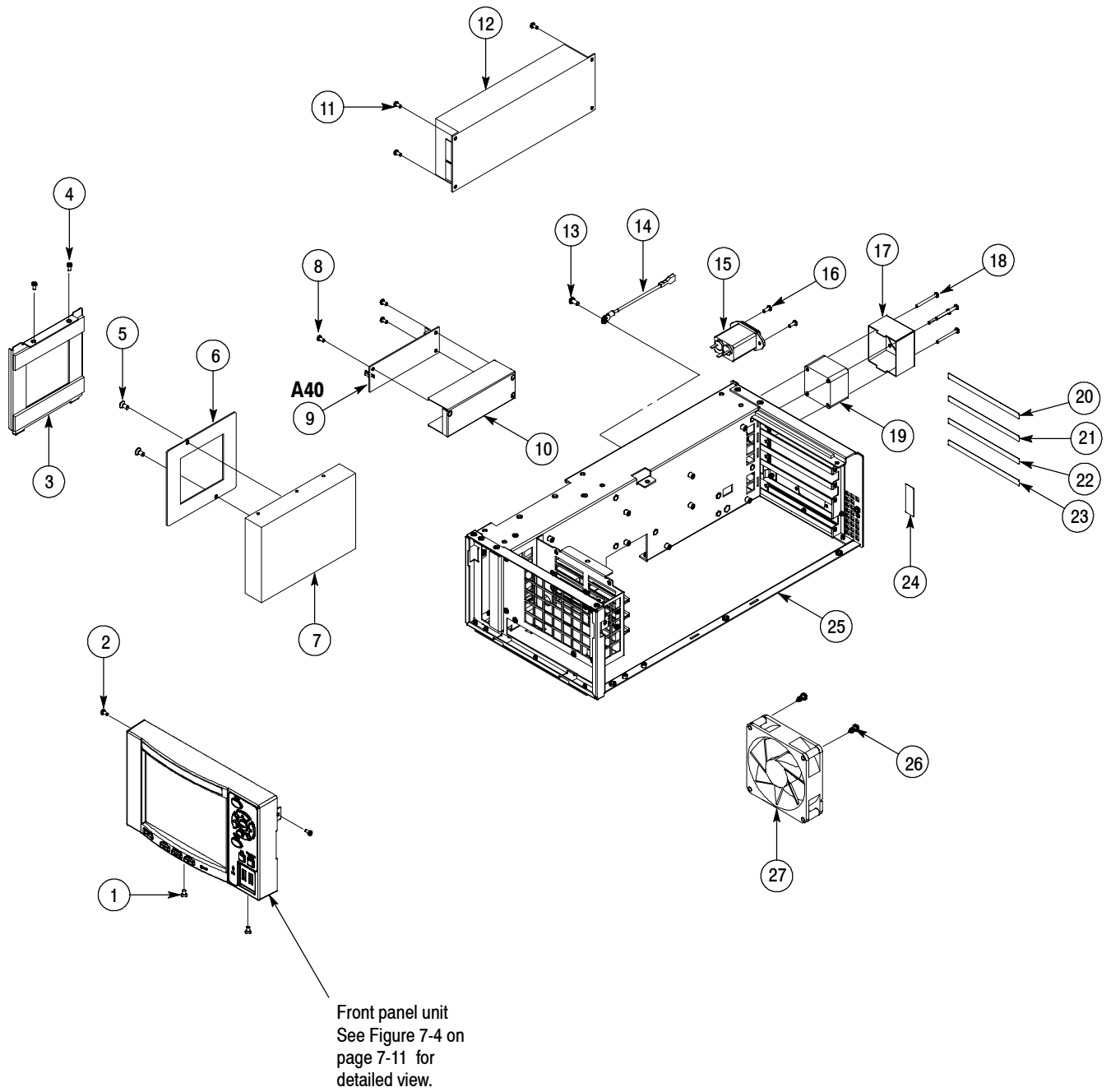

Figure 7-1: Cabinet and covers

**Replaceable parts list**

Fig. & index number	Tektronix part number	Serial no. effective	Serial no. discont'd	Qty	Name & description
7-2-1	211-0734-00			2	SCREW,MACHINE:6-32X0.25,FLH,100 DEG,STL ZN-CM1,T10 TORX
-2	211-0373-00			2	SCREW,MACHINE:4-40X0.25,PNH,STL ZN-CM1,T10 TORX
-3	343-1708-00			1	RETAINER:HARD DISK DRIVE,W/POLYURETHANE,MTX100A,AL
-4	211-0734-00			2	SCREW,MACHINE:6-32X0.25,FLH,100 DEG,STL ZN-CM1,T10 TORX
-5	211-0734-00			2	SCREW,MACHINE:6-32X0.25,FLH,100 DEG,STL ZN-CM1,T10 TORX
-6	386-7460-00			1	PLATE:HDD,AL
-7	650-4862-00			1	HARD DISK DRIVE:160GB,3.5 INCH,7200RPM,ATA-100
-8	211-0373-00			3	SCREW,MACHINE:4-40X0.25,PNH,STL ZN-CM1,T10 TORX
-9	671-5979-00			1	CIRCUIT BD ASSY;A40,SUB POWER,389-3738-00 WIRED
-10	342-1138-00			1	INSULATOR:CKT BOARD,POLYCARBONATE,A40 BOARD
-11	211-0373-00			4	SCREW,MACHINE:4-40X0.25,PNH,STL ZN-CM1,T10 TORX
-12	119-7147-00			1	POWER SUPPLY;85V-264VAC IN,12VDC 12.5A OUT,LEA150F-12-R,COSEL
-13	211-0711-00			1	SCR,ASSEM WSHR;6-32X0.250,PNH,STL,CDPL,T-15 TORX DR,MACHINE,W/SQ CONE WASHER
-14	196-3496-00			1	LEAD,ELECTRICAL;18 AWG,4.0 L,5-4 SAFETY CONTROLLED
-15	119-6009-00			1	FILTER,RFI;3A,250VAC,0.5,MA,0.15OHM;SAFETY CONTROLLED
-16	211-0372-00			2	SCREW,MACHINE:4-40X0.312,PNH,STL ZN-CM1,T10 TORX
-17	200-4974-00			1	COVER,FAN;REAR,MTX100A,AL
-18	211-1161-00			4	SCREW,MACHINE;4-40X1.500,PNH HEAD,T-10 TORX,ZINC PL
-19	119-7186-00			1	CABLE,ASSEMBLY,4,18AWG,60MM L,HDD POWER(40 SQ FAN)
-20	335-1365-00			1	MARKER,IDENT:MKD CONNECTORS FOR A100 (OPTION 01)
	335-1366-00			1	MARKER,IDENT:MKD CONNECTORS FOR A110 (OPTION 02)
	335-1367-00			1	MARKER,IDENT:MKD CONNECTORS FOR A140 (OPTION 05)
	335-1368-00			1	MARKER, IDENT:MKD CONNECTORS FOR A170 (OPTION 07)
-21	335-1364-00			1	MARKER,IDENT:MKD CONNECTORS FOR A12,POLYCARBONATE
-22	335-1363-00			1	MARKER,IDENT:MKD CONNECTORS PRINTER&IEEE1394B,POLYCARBONATE
-23	335-1362-00			1	MARKER,IDENT:MKD CONNECTORS FOR CPU BD,POLYCARBONATE
-24	335-0133-00			1	MARKER,IDENT;BLANK LABEL FOR MES LINES; THT-37-483-10MONOCHROME DISPLY;TDS300,TDS400 SERIES,SAFETY COTROLLED
-25	441-2404-00			1	CHASSIS,ASSY;MAIN,MTX100A,AL
-26	210-0164-000			2	RIVET,SOLID;0.163 ODX0.415 L,PANEL RANGE HEAD STYLE,NYLON
-27	119-7187-00			1	FAN 119569400 W/CABLE 18CM L(92 SQ FAN)



**Figure 7-2: Internal modules (1)**

**Replaceable parts list**

Fig. & index number	Tektronix part number	Serial no. effective	Serial no. discont'd	Qty	Name & description
7-3-1	650-4981-00			1	PROCESSOR MODULE W/BRACKET+LABEL 334A48100
-2	671-5975-00			1	CIRCUIT BD ASSY;A12,MAIN,389-3734-00 WIRED
-3	671-6118-00			1	CIRCUIT BD ASSY;A100(OPTION 01)
	671-6119-00			1	CIRCUIT BD ASSY;A110(OPTION 02)
	671-6120-00			1	CIRCUIT BD ASSY;A140(OPTION 05)
	671-6141-00			1	CIRCUIT BD ASSY;A170(OPTION 07)
-4	211-0373-00			10	SCREW,MACHINE:4-40X0.25,PNH,STL ZN-CM1,T10 TORX
-5	671-5976-00			1	CIRCUIT BD ASSY;A20,PCI BACK PANEL,389-3735-00 WIRED
-6	174-5190-00			1	CABLE ASSEMBLY,28AWG FLAT,1.27CTR,W/CONN D-SUB25&2X13
-7	210-0054-00			2	WASHER,LOCK;#4 SPLIT,0.025 THK STL CD PL
-8	214-3903-01			2	SCREW,JACK:4-40X0.312 EXT THD,4-40 INT THD,0.188 HEX,STEEL,CAD PLATE
-9	211-0373-00			4	SCREW,MACHINE:4-40X0.25,PNH,STL ZN-CM1,T10 TORX
-10	333-4518-00			1	PANEL,PCI:BLANK,NI PL,STL
-11	211-0373-00			4	SCREW,MACHINE:4-40X0.25,PNH,STL ZN-CM1,T10 TORX
-12	211-0373-00			3	SCREW,MACHINE:4-40X0.25,PNH,STL ZN-CM1,T10 TORX
-13	426-2624-00			1	FRAME,SECTION:TOP,MTX100A,STL
-14	211-0373-00			2	SCREW,MACHINE:4-40X0.25,PNH,STL ZN-CM1,T10 TORX
-15	343-1697-00			2	RETAINER:CKT BD,PCI,MTX100A,STL

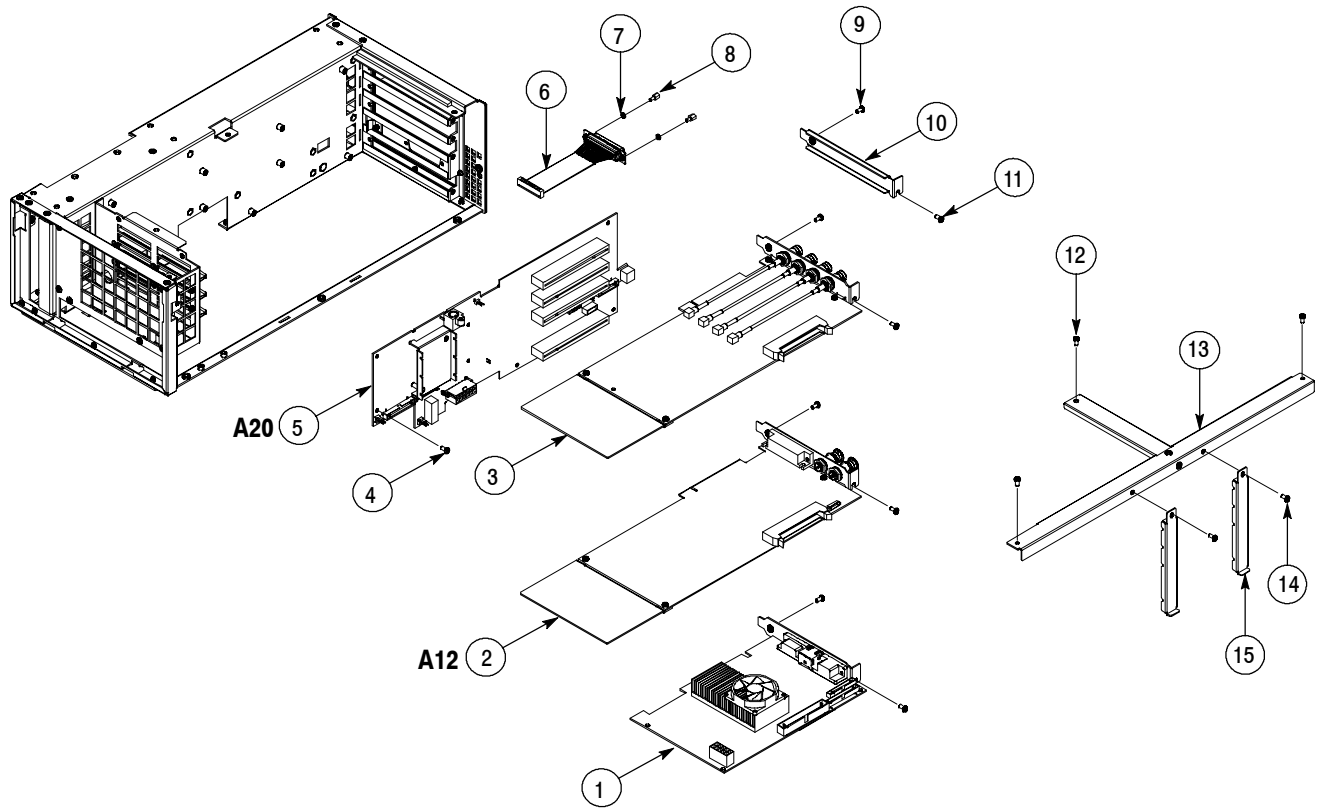

Figure 7-3: Internal modules (2)

**Replaceable parts list**

Fig. & index number	Tektronix part number	Serial no. effective	Serial no. discont'd	Qty	Name & description
7-4-1	335-1596-00			1	MARKER,IDENT:LABEL,MTX100B,POLYCARBONATE,SAFETY CONTROLLED
-2	101-0175-00			1	TRIM;FRONT BEZEL,PC/ABS,TV GRAY,MTX100B,SAFETY CONTROLLED
-3	337-4389-00			1	SHIELD,DISPLAY;5.568 X 4.221,0.090 THICK,0.050 THICK GLASS,0.040 BLACK PORON W/0.002 THK ADHESIVE;MTX100B
-4	211-0373-00			4	SCREW,MACHINE:4-40X0.25,PNH,STL ZN-CM1,T10 TORX
-5	119-7205-00			1	DISPLAY MODULE;LCD,COLOR;1024X768 (XGA),6.3 DIAG,TFT,8/6-BIT LVDS,250 NIT BACK LIGHT,0.125 MM PIXEL PITCH,21MS,FRONT MOUNT,NL10276BC-02,SAFETY CONTROLLED
-6	407-5197-00			1	BRACKET;DISPLAY/FRONT PANEL,AL,MTX100B
-7	174-5266-00			1	CA ASSY;RIBBON ADAPTER TO XGA DISPLAY,20 PIN,3.5IN
-8	174-3767-01			1	CABLE ASSY,SP;DISCRETE,BACKLIGHT,IDC,26 AWG,5.0 L,PCB,1 X 6,0.079 CTR (2MM),SHRINK WRAPPED
-9	119-5999-00			1	POWER SUPPLY;INVERTOR BOARD,REPLACEMENT FOR LCD 119-5659-00 6.5 LCD
-10	211-1117-00			2	SCREW,MACHINE:4-40 X 0.187,PAN HEAD,STL,CD PL,T-10,TORX DR
-11	335-0577-00			1	LABEL,MANUFACTURED;PRODUCT ID,2.5 IN X 1.5 IN,SAFETY CONTROLLED
-12	211-1117-00			4	SCREW,MACHINE:4-40 X 0.187,PAN HEAD,STL,CD PL,T-10,TORX DR
-13	679-6251-00			1	CIRCUIT BD ASSY,UNTESTED,389388900 WIRED;FRONT PANEL PROCESSOR, MTX100B
-14	337-4390-00			1	SHIELD ELEC;KEYPAD BOARD,0.020 THK POLYCARBONATE,LEXAN FR60,MTX100B, SAFETY CONTROLLED
-15	679-6250-00			1	CIRCUIT BD ASSY,UNTESTED,389388800 WIRED;KEYBOARD;L-SHAPE,MTX100B
-16	211-0373-00			2	SCREW,MACHINE:4-40X0.25,PNH,STL ZN-CM1,T10 TORX
-17	260-2834-00			1	SWITCH,KEYPAD;ELASTOMERIC FRONT PANEL MTX100B
-18	260-2835-00			1	SWITCH,ELASTOMERIC,POWER AND PLAY BUTTONS;FRONT PANEL MTX100B
-19	335-1595-00			1	LABEL,FRONT PANEL CONTROL,MTX100B



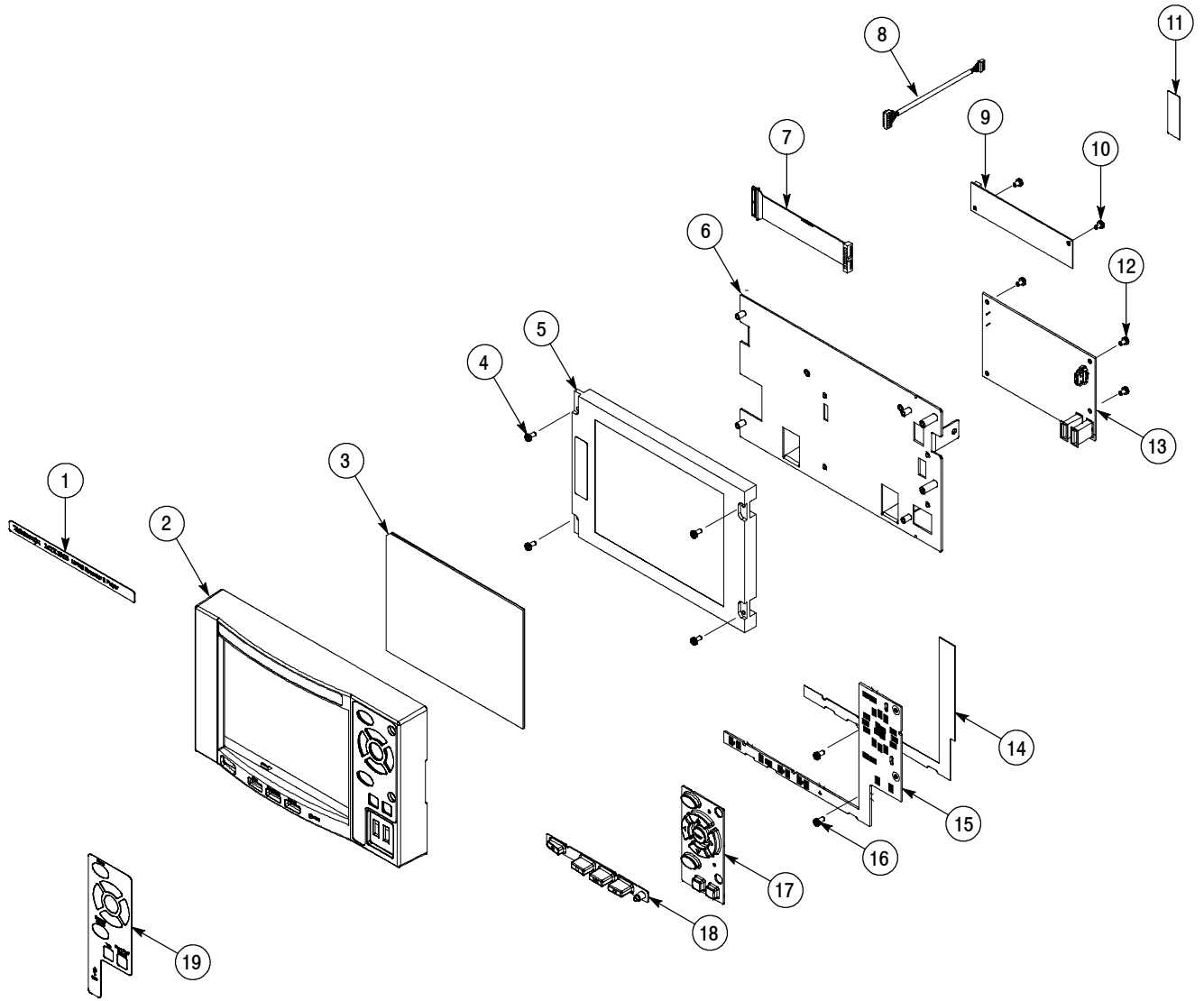

Figure 7-4: Front-panel unit

**Replaceable parts list**

Fig. & index number	Tektronix part number	Serial no. effective	Serial no. discont'd	Qty	Name & description
7-5-1	174-5183-00			1	CABLE,ASSEMBLY,2X20,FLAT,430MM L,ULTRA ATA (CPU-HDD,HDD IDE)
-2	174-5181-00			1	CABLE,ASSEMBLY,4,18AWG,60MML,HDD POWER (HDD-A20,POWER)
-3	174-5172-00			1	CABLE,ASSEMBLY,2,22AWG,50MM L,W/CONN 22-01-3027(MOLEX),(A20-A4-,5V STAND-BY)
-4	174-5177-00			1	CABLE,ASSEMBLY,7,18AWG,50MM I;VHR-10N&VHR-7N+XHP-2(JST),(P/S-A20,POWER&CONTROL)
-5	174-5178-00			1	CABLE,ASSEMBLY,6,18AWG,110MM L,W/CONN VHR-6N(JST),(P/S-A20,GND)
-6	174-5171-00			1	CABLE,ASSEMBLY,2,18AWG,130MM I,W/CONN VHR-5N(JST) (P/S-A40)
-7	174-5170-00			1	CABLE,ASSEMBLY,2,18AWG,40MM I,AC INLET to A40(INLET-A40)
-8	196-3449-00			1	LEAD,ELECTRICAL;18AWG,4.0 L,5-4 SAFETY CONTROLLED
-9	119-7186-00			1	CABLE,ASSEMBLY,SP,ELEC;FAN 119B05500 W/CABLE,10CM L (40 SQ FAN)
-10	174-B924-00			1	CABLE,ASSEMBLY,SP,ELEC:80,30AWG,5CM L,FLAT,W/CONN(YAMAICHI)
-11	174-5190-00			1	CABLE,ASSEMBLY,28AWG FLAT,1.27CTR,W/CONN D-SUB25&2X13(DSUB25-CPU)
-12	174-5186-00			1	CABLE,ASSEMBLY,2X10,28AWG FLAT,1MM CTR,130MM L,RS232C SLOT PC TO A20 (CPU-A20,RS2-232C)
-13	174-5348-00			1	CABLE,ASSEMBLY,2X5,28AWG FLAT,1MM CTR,120MM L,PANNEL SLOT PC TO A20 (CPU-A20,PANEL CONTROL)
-14	174-5184-00			1	CABLE,ASSEMBLY,14,30AWG 7TWISTED PAIRS,270MM L,LVDS SLOT PC TO A20, (CPU-A20,LCD LVDS)
-15	174-5174-00			1	CABLE,ASSEMBLY,12,18AWG,150MM L,SLOT PC POWER(CPU-A20,CPU POWER)
-16	119-7187-00			1	CABLE,ASSEMBLY,SP,ELEC;FAN 119569400 W/CABLE 18CM L (92 SQ FAN)
-17	174-5188-00			1	CABLE,ASSEMBLY,SP,ELEC;10,60CM L,26AWG AND 28 AWG(CPU-A35,USB)
-18	174-5220-00			1	CABLE,ASSEMBLY,2X15,28AWG FLAT,1MM CTR,300MM L,A20 TO A30
-19	174-3767-01			1	CABLE,ASSEMBLY,SP;DISCRETE,BACKLIGHT,IDC,26 AWG,5.0 L,PCB,1 X 6,0.079 CTR (2MM),SHRINK WRAPPED
-20	174-5266-00			1	CABLE,ASSEMBLY;RIBBON ADAPTER TO XGA DISPLAY,10 PIN,3.5IN

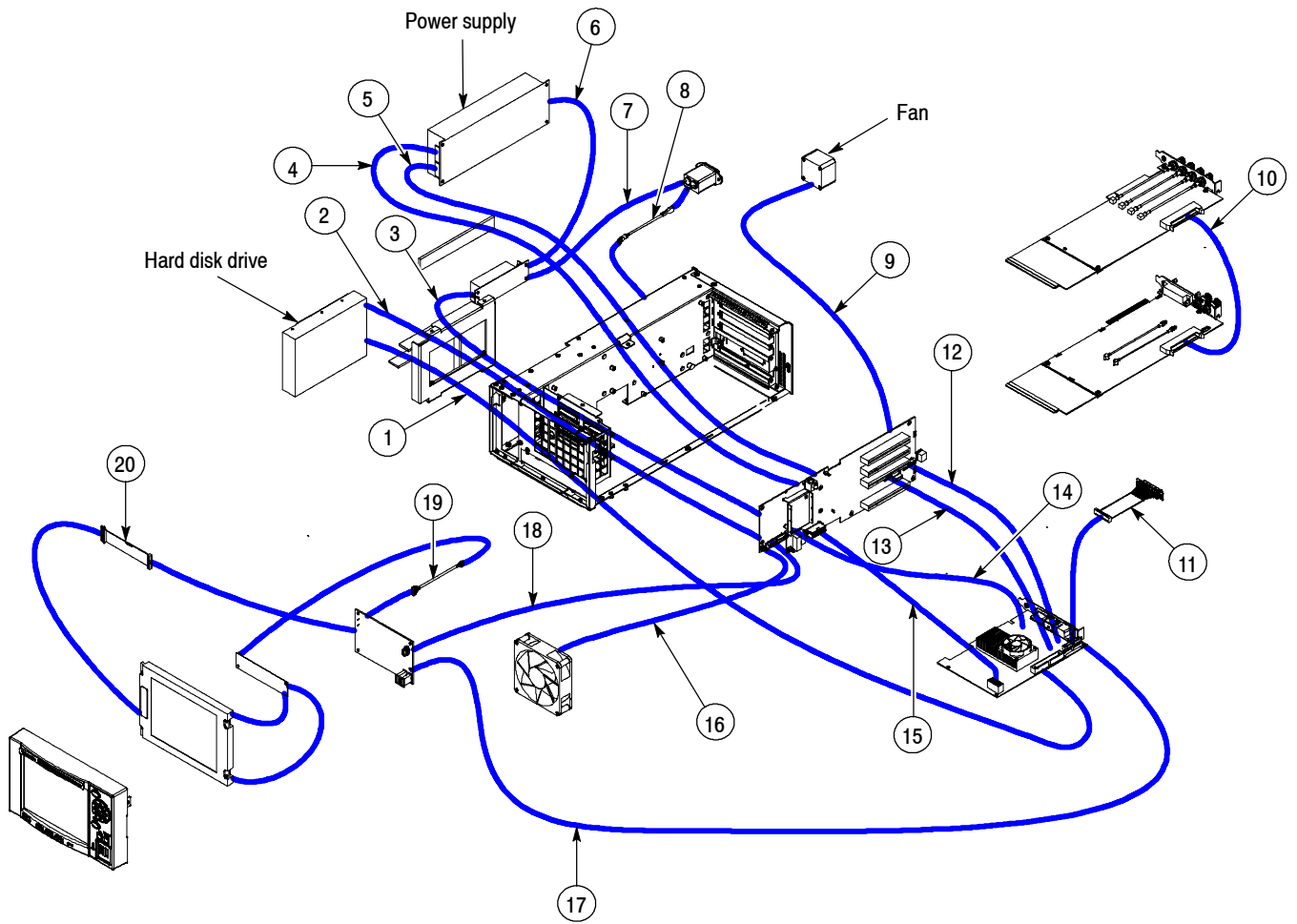

Figure 7-5: Cables

**Replaceable parts list**

Component number	Tektronix part number	Serial no. effective	Serial no. discont'd	Qty	Name & description
<b>STANDARD ACCESSORIES</b>					
	071-1927-XX			1	MANUAL,TECH,USER,MTX100B,ENGLISH (OPTION L0)
	071-1928-XX			1	MANUAL,TECH,USER,MTX100B,JAPANESE (OPTION L5)
	063-3932-XX			1	SOFTWARE PKG:SAMPLE STREAM,CD-ROM
	012-A220-00			1	CABLE,INTCON:D-SUB 25,MALE TO MALE,STR,TWIST,2M L,SCREW 4-40
	119-6936-00			1	POINTER ASSY:OPTICAL MOUSE,USB,WHITE,OPTICAL THREE BUTTON WHEELED,W/USB to PS2 ADAPTER,ABS,SAFETY CONTROLLED
	119-B146-00			1	KEYBOARD:USB;MTX100,SAFETY CONTROLLED
	200-4716-00			1	COVER,FRONT;PROTECTIVE,PC/ABS FR110,W/TAPE;TV GRAY
	161-0066-00			1	CABLE ASSY,PWR; 3,18 AWG,250V/10A,98.0 L,STR,IEC320, RCPT X NEMA 5-15P,US,SAFETY CONTROLLED
	161-0066-09			1	CABLE ASSY,PWR; 3,0.75MM SQ,250V/10A,99.0 L,STR, IEC320,RCPT,EUROPEAN,SAFETY CONTROLLED
	161-0066-10			1	CABLE ASSY,PWR;3,1.0MM SQ,250V/10A,2.5 METER,STR,IEC320,RCPT X 13A,FUSED UK PLUG(13A FUSE),UNITED KINGDOM,SAFETY CONTROLLED
	161-0066-13			1	CABLE ASSY,PWR;3,1.0MM SQ,250V/10A,2.5 METER, STR,IEC320,RCPT,AUSTRALIA,SAFETY CONTROLLED
	161-0066-12			1	CABLE ASSY,PWR;3,18 AWG,250V/10A,98.0 L,STR,RCPT X NEMA 6-15P,US,SAFETY CONTROLLED
	161-0154-00			1	CABLE ASSY,PWR;3,1.0MM SQ,250V/10A,2.5 METER, STR,IEC320,RCPT,SWISS,SAFETY CONTROLLED
	161-0298-00			1	CABLE ASSY,PWR; 3,125V/7A,JAPAN,98 LONG,STR,NEMA 5-15P PLUG X IEC320/C-13 RECEPTACLE,SAFETY CONTROLLED
	161-0304-00			1	CABLE ASSY,PWR;3,1.0MM SQ,250V/10A,2.5 METER, STR,IEC320,3C CERTIFICATION,RCPT,CHINA,SAFETY CONTROLLED
<b>OPTIONAL ACCESSORIES</b>					
	071-1929-XX			1	MANUAL,TECH:SERVICE,MTX100B
	-----			1	1700F05 SIDE-BY-SIDE RACK ADAPTER
	-----			1	1700F06 BLANK PANEL